

SONY®



PlayStation®5

Quick Start Guide

Vodič za brzi početak • Ghid de pornire rapidă

Кратко ръководство • Vodič za brzo pokretanje

Οδηγός γρήγορης έναρξης • Hızlı Başlangıç Kılavuzu

Let's get started

1 Insert the horizontal stand feet into the hole in the grooves of the PlayStation®5 console.

Always attach the feet to your PS5® console before use. Place your console on a soft cloth spread over a flat surface before attaching the feet.

Console with disc drive installed

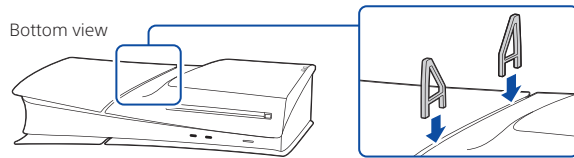

Console without disc drive installed

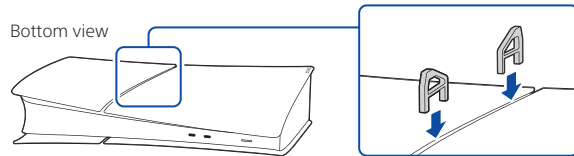

If you want to set your PS5 console in the vertical position, you'll need to use the vertical stand (sold separately).

2 Connect the HDMI cable and the AC power cord.

Use the included cables. Make all connections before plugging the AC power cord into an electricity supply.

The following illustrations all show the console with the disc drive installed.

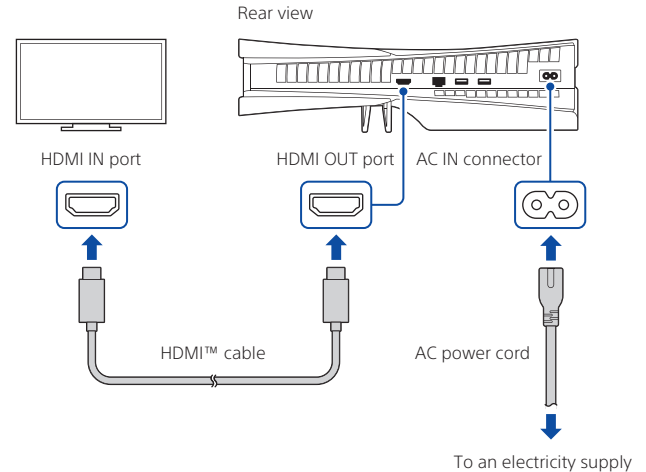

3 Connect the LAN cable.

For a wired connection to the internet, use a LAN cable (not included).
If you're going to use Wi-Fi®, don't connect a LAN cable and skip to the next step.

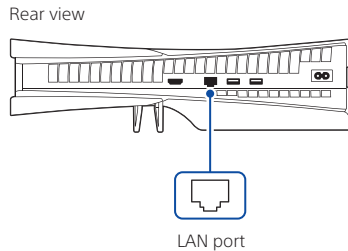

4 Turn on your TV and set the input to HDMI.

5 Turn on your PS5 console by pressing the ⏻ (power) button.

The power indicator blinks blue, and then turns white.

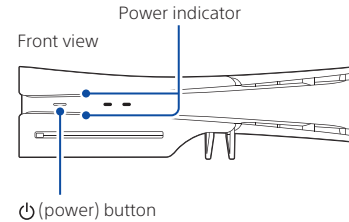

If you leave the console idle for 60 seconds after you turn it on, the screen reader turns on. You can listen to on-screen text and other important information read aloud to help you accomplish what you want to do.
Screen reader is available only in certain languages.

6 Connect your DualSense® wireless controller to your console and press the (PS) button.

To pair your controller, connect it with a USB cable to the USB port on your console. When you press the  (PS) button, the controller turns on.

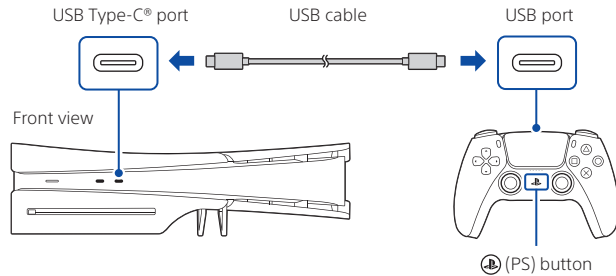

7 Make it your own.

You're almost done! Follow the on-screen instructions to complete the initial setup.

- Set up your account
Make a new account or sign in with an existing account. By signing in with your existing account, you can access your PlayStation®Plus subscription, as well as friends, trophies, and other account information.
- Transfer data from another console
If you have a PlayStation®4 console or another PS5 console, you can transfer data to your new console by signing in with an existing account.

You'll know that setup is complete when **Welcome to PlayStation 5** appears on your screen.

Will a child be using your PS5 console? See also "Parental controls" (page 5).

- The setup options that you see are tailored to your needs, based on information such as your network environment and the account that you're signed into.
- You can go back and change any of your settings by selecting **Settings**  from the home screen.

Parental controls

You can manage settings for children who use your PS5 console. Parental controls let you set restrictions on the games children can play, when and how long they play, whether or not they can chat, and more.

Each adult (👤) and child (👶) will need their own separate accounts. When you create an account for a child, it's automatically linked to your account, creating a family. You can set parental controls only for children in your family.

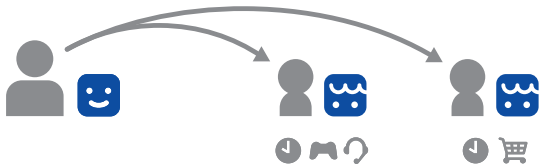

You can use an existing account, such as one you created on a PS4™ console, for your PS5 console. Your family and parental control settings will carry over to your PS5 console.

Create an account for a child

You can create a child account and set parental controls at the same time.

Press the **(PS)** button to open the control centre. Select your profile picture, then select **Switch User**. From the user selection screen, select **Add User** to create an account.

Review and change your parental control settings





We recommend that you check the child's parental controls regularly. You can review or update them by selecting **Settings** ⚙️ > **Family and Parental Controls** from the home screen.

Parental controls





Game rating icons

Each game comes with a game rating icon that helps you determine whether it's age-appropriate for the child.

Europe, Africa and India

Player's Age	3 and above	7 and above	12 and above	16 and above	18 and above
Game Age Rating					

Germany

Player's Age	0 and above	6 and above	12 and above	16 and above	18 and above
Game Age Rating					

Find out more about parental control features and setup in the User's Guide (page 12).

What's on the screen

Home screen

From the home screen, you can go to two types of content: games or media. In the games home, you'll find your games, PlayStation™Store, and other game-related apps. In the media home, you'll find music, video, and other non-game related apps.

EN

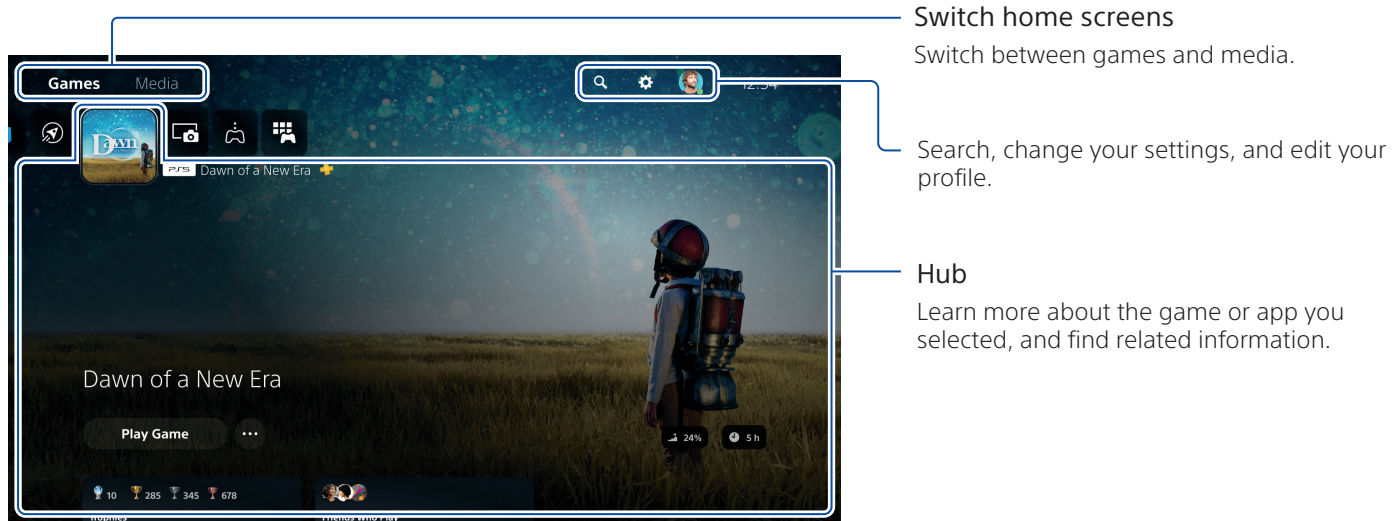

- On the PS5 console, the **X** button confirms selected items.
- To return to the home screen while your game or app is running, select **Home**  from the control centre, or press and hold the **PS** button on your controller.

What's on the screen

Control centre

Press the  (PS) button to open the control centre.



You can access a variety of features without leaving your game or app.



Cards

Cards show you features and activities related to your games and apps that are available depending on what you're doing at that moment. Select a card to learn more, or jump to the next card.

Controls

Select **Home**  to return to your home screen, and **Power**  to turn off your PS5 console. Perform other basic functions here, too.

Get quick access to the functions and settings you use most during gameplay.

Let's play

Play a digital game

You can play a game that you downloaded from **PlayStation Store** .

You'll get a notification when the game is downloaded and ready to play.

Select the game from your games home.

- To purchase and download games, you'll need to connect your console to the internet and sign in with your account.
- PlayStation™ Network and PlayStation Store subject to terms of use and country and language restrictions. Users are responsible for internet service fees. Charges apply for some content and/or services. Users must be 7 years or older and users under 18 require parental consent. Additional age restrictions may apply. Service availability is not guaranteed. Online features of specific games may be withdrawn on reasonable notice - [playstation.com/gameservers/](https://www.playstation.com/gameservers/). Full terms apply: PSN Terms of Service at [playstation.com/legal/](https://www.playstation.com/legal/).

Play a game from a disc

(Only for consoles with disc drive installed)

Insert the disc.

Game data will begin to install, and you'll receive a notification when the game is ready to play.

Select the game from your games home.

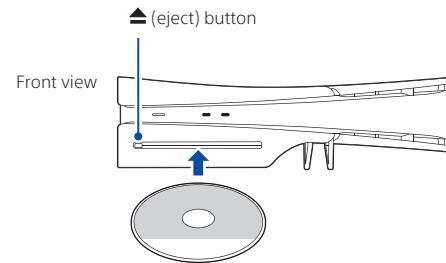

Eject the disc

Press the  (eject) button to eject the disc.

Use your controller

Charge your controller

With your PS5 console turned on or in rest mode, use a USB cable to connect your controller to the console. When your console is in rest mode, the light bar on your controller slowly blinks orange. After charging is complete, the light bar turns off.

To charge your controller while your console is in rest mode, go to **Settings** ⚙️ > **System** > **Power Saving** > **Features Available in Rest Mode** > **Supply Power to USB Ports**, and select an option other than **Off**.

Mute your microphone

Each time you press the mute button, your mic switches between muted (button lit) and unmuted (button off).

Press and hold the mute button to mute your mic and to turn off sound output from the speakers on your controller and TV. Press the mute button again to return to the original state.

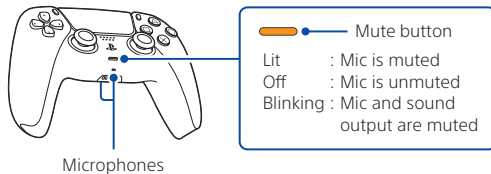

Use multiple controllers

You can use up to 4 controllers at once. Press the  (PS) button to assign numbers to your controllers. The player indicator lights turn on accordingly. Numbers are assigned in order from 1, and you can determine your controller's number by the number of lights that turn on.

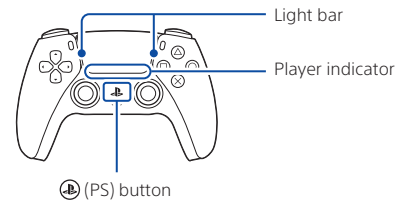

- You'll need to pair your controller when you use it for the first time (page 4).
- When you play a PS4 game, your controller's light bar glows blue, red, green, or pink based on the order that the controller is connected. This is separate from the player indicator.

Turn on your PS5 console with a controller

Press the  (PS) button on a controller that has finished pairing to turn on your PS5 console.

Shutting down



Caution

Disconnect the AC power cord from the electricity supply only when the power indicator is off. If you disconnect it while the power indicator is on solidly or blinking, data might be lost or become corrupted, and you might damage your console.

Put your console in rest mode

Your PS5 console's power saving mode is called rest mode. You can do things like charge your controller via the console's USB ports, automatically update your system software, and keep your game or app suspended while powered down. To find out which rest mode settings are optimal for you, see the User's Guide (page 12).

For some features, you'll need to enable their settings to use them. Go to **Settings**  > **System** > **Power Saving** > **Features Available in Rest Mode**.

Select **Power**  from the control centre, and then select **Enter Rest Mode**. The power indicator blinks white, and then turns orange. To exit rest mode, press the  (PS) button.

Turn off your console completely

Select **Power**  from the control centre, and then select **Turn Off PS5**. The power indicator blinks white, and then the console turns off.

Power indicator

White	Console is on.
Orange	Console is in rest mode.
Off	Console is off.

Further information

Safety Guide

Learn how to use your PS5 console safely with the supplied Safety Guide. This printed manual also contains product warranty terms and information about specifications. Be sure to read it before using your console.

User's Guide

Find out about everything your PS5 console can do. Learn how to configure settings and how to use each function. From your PS5 console's home screen, go to **Settings** ⚙️ > **User's Guide, Health and Safety, and Other Information** > **User's Guide**.

Customer Support Website

Find online support information such as step by step troubleshooting and frequently asked questions by visiting playstation.com/help/.



“PS”, “PlayStation”, “PS5”, “PS4”, “DualSense” and “PlayStation Shapes Logo” are registered trademarks or trademarks of Sony Interactive Entertainment Inc. “SONY” and “PS” are registered trademarks or trademarks of Sony Group Corporation. The terms HDMI, HDMI High-Definition Multimedia Interface, HDMI Trade dress and the HDMI Logos are trademarks or registered trademarks of HDMI Licensing Administrator, Inc. USB-IF SuperSpeed USB Trident logo is a registered trademark of USB Implementers Forum, Inc. USB Type-C® and USB-C® are registered trademarks of USB Implementers Forum. Wi-Fi® is a registered trademark of Wi-Fi Alliance®.

Design and specifications are subject to change without notice. Information about system functionality and images published in this document may vary from those for your console, depending on the system software version in use. Also, the illustrations and screen images used in this guide may vary from the actual product. The information contained in this guide is subject to change without notice.

Započnimo

1 Umetnite noge za vodoravni stalak u utor u udubine konzole PlayStation®5.

Uvijek pričvrstite noge na konzolu PS5® prije upotrebe. Postavite konzolu na raširenu meku krpu na ravnu površinu prije pričvršćivanja noga.

Konzola uz instalirani diskovni pogon

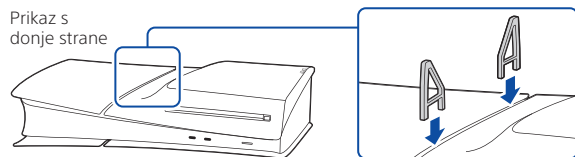

Konzola bez instaliranog diskovnog pogona

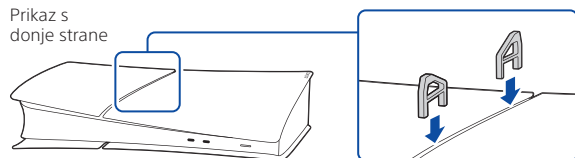

Ako želite postaviti svoju konzolu PS5 u okomiti položaj, trebat ćete upotrijebiti stalak za okomito postavljanje (prodaje se zasebno).

2 Povežite HDMI kabel i kabel za napajanje izmjeničnom strujom.

Upotrijebite priložene kabele. Povežite sve spojeve prije priključivanja kabela za napajanje izmjeničnom strujom u električnu utičnicu.

Sve sljedeće slike prikazuju konzolu uz instalirani diskovni pogon.

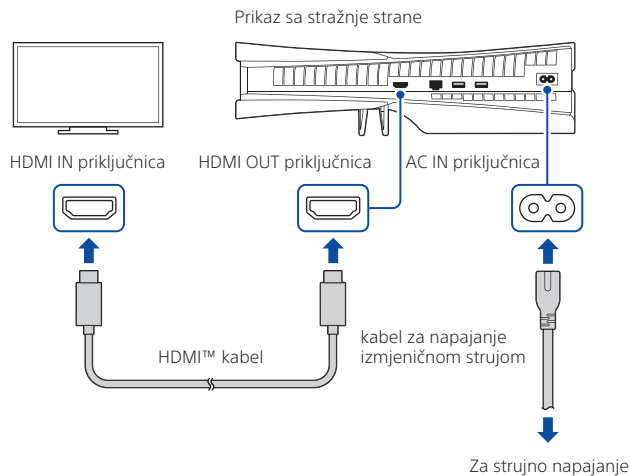

3 Povežite LAN kabel.

Za žičanu vezu na internet upotrijebite LAN kabel (nije isporučen).

Ako ćete upotrebljavati vezu Wi-Fi®, nemojte povezivati LAN kabel i preskočite sljedeći korak.

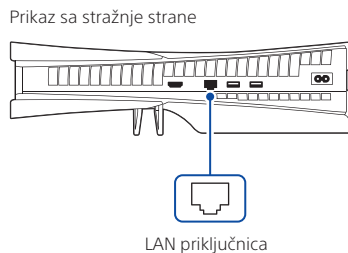

4 Uključite televizor i postavite ulaz na HDMI.

5 Uključite svoju konzolu PS5 tako da pritisnete gumb (napajanje).

Indikator napajanja treperi plavo, a zatim počinje svijetliti bijelo.

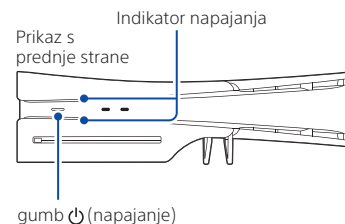

Ako konzolu ostavite u stanju mirovanja 60 sekundi nakon uključivanja, uključit će se čitač zaslona. Možete slušati tekst s ekrana i druge važne informacije kako biste dobili pomoć koju trebate.
Čitač zaslona dostupan je samo na nekim jezicima.

6 Povežite svoj DualSense® bežični upravljač na konzolu i pritisnite gumb (PS).

Za uparivanje upravljača povežite ga s USB kabelom na USB priključnicu na svojoj konzoli. Upravljač će se upaliti kada pritisnete gumb  (PS).

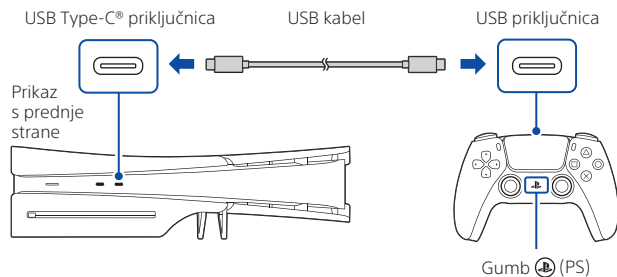

7 Prilagodite ga prema željama.

Pri kraju ste! Za početno postavljanje slijedite upute na zaslonu.

- Postavljanje računa
Izradite novi račun ili se prijavite uz postojeći. Prijavom uz postojeći račun možete pristupiti svojoj pretplati za PlayStation®Plus, kao i prijateljima, trofejima i ostalim informacijama o računu.
- Prijenos podataka s druge konzole
Ako imate konzolu PlayStation®4 ili drugu konzolu PS5, možete prenijeti podatke na novu konzolu prijavom na postojeći račun.

Postavljanje je dovršeno kada se na zaslonu pojavi poruka **Welcome to PlayStation 5 (Dobrodošli na konzolu PlayStation 5)**.

Hoće li vašu konzolu PS5 upotrebljavati djeca? Pogledajte „Roditeljski nadzor“ (stranica 17).

- Opcije postavki koje vidite kreirane su prema vašim potrebama i temelje se na podacima kao što su mrežno okruženje i račun na koji ste prijavljeni.
- Možete se vratiti i promijeniti bilo koje postavke odabirom **Settings (Postavke)**  fna početnom zaslonu.

Roditeljski nadzor

Postavke za djecu koja se koriste vašom konzolom PS5 mogu se prilagoditi. Roditeljski nadzor omogućuje postavljanje ograničenja za igre koje djeca smiju igrati, kada smiju igrati i koliko dugo, smiju li se služiti opcijom razgovora ili ne te još mnogo toga.

Svakoj odrasloj osobi (👤) i djetetu (👶) bit će potrebni odvojeni računi. Kada stvorite račun za dijete, on je automatski povezan s vašim računom, što stvara obitelj. Roditeljski nadzor možete postaviti samo za djecu u svojoj obitelji.

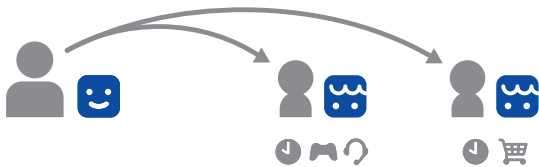

Za svoju konzolu PS5 možete upotrijebiti već postojeći račun, primjerice račun stvoren na konzoli PS4. Postavke obiteljskog i roditeljskog nadzora prenijet će se na vašu konzolu PS5.

Stvaranje računa za dijete

Istovremeno možete stvoriti račun za dijete i postaviti roditeljski nadzor.

Pritisnite gumb **PS** za otvaranje kontrolnog centra. Odaberite profilnu sliku i potom **Switch User (Promijeni korisnika)**. Na zaslonu za odabir korisnika odaberite **Add User (Dodaj korisnika)** da biste kreirali račun.

Pregled i promjena postavki roditeljskog nadzora

Preporučamo da redovito provjeravate roditeljski nadzor. Možete ih pregledati i ažurirati tako da na početnom zaslonu odaberete gumb **Settings (Postavke) > Family and Parental Controls (Obiteljski i roditeljski nadzor)**.

Roditeljski nadzor

Ikone ocjene igre

Svaka igra ima ikonu ocjene igre koja vam pomaže odrediti je li igra prikladna za dob vašeg djeteta.

Europa, Afrika i Indija

Dob igrača	3 godine i više	7 godina i više	12 godina i više	16 godina i više	18 godina i više
Dobna klasifikacija igre					

Njemačka

Dob igrača	0 godina i više	6 godina i više	12 godina i više	16 godina i više	18 godina i više
Game Age Rating					

Saznajte više o značajkama roditeljskog nadzora i postavljanju u Uputama za upotrebu (stranica 24).

Što je na zaslону?

Početni zaslon



S početnog zaslona možete otvoriti dvije vrste sadržaja: igre ili medije.

Na početnom zaslonu Igre možete pronaći svoje igre, trgovinu PlayStation™Store i druge aplikacije povezane s igrom.

Na početnom zaslonu Multimedijски sadržaj možete pronaći igre, videozapise i druge aplikacije koje nisu povezane s igrom.

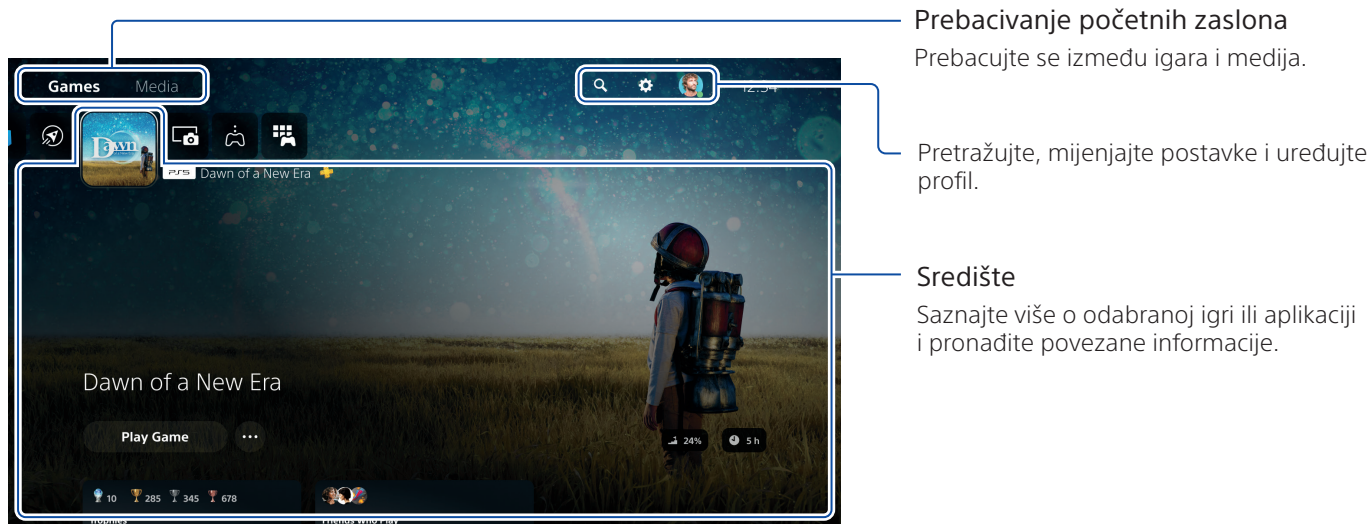
HR



- Na konzoli PS5 gumb  potvrđuje odabrane stavke.
- Za povratak na početni zaslon tijekom pokrenute igre ili aplikacije, odaberite gumb  Home (Početni zaslon) u kontrolnom centru ili pritisnite i zadržite gumb  (PS) na upravljaču.

Što je na zaslonu?

Kontrolni centar

Pritisnite gumb  (PS) za otvaranje kontrolnog centra.

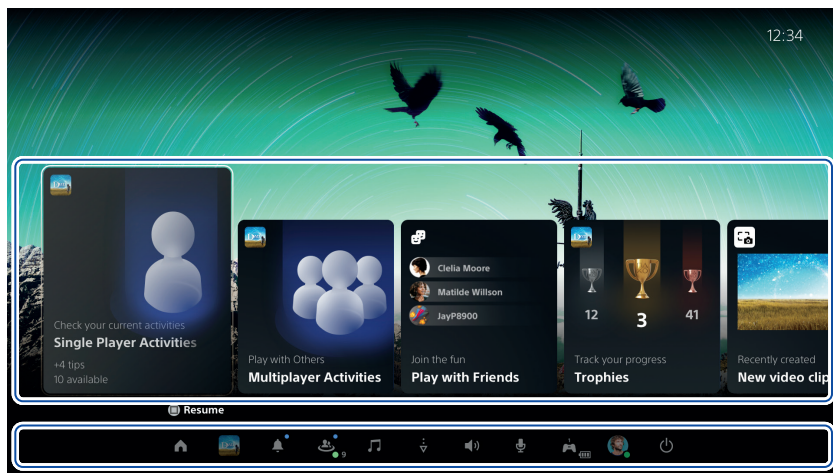

Možete pristupiti raznim značajkama, a da ne napustite igru ili aplikaciju.



Kartice

Kartice prikazuju značajke i aktivnosti koje su povezane s vašim igrama i aplikacijama i dostupne, ovisno o tome što radite u tom trenutku. Za više informacija odaberite karticu ili prijedite na sljedeću.

Kontrole

Odaberite ikonu  Home (Početni zaslon) za povratak na početni zaslon te odaberite ikonu  Power (Napajanje) za isključivanje konzole PS5. Ovdje možete izvršavati i druge osnovne funkcije.

Brzo pristupite funkcijama i postavkama koje najčešće upotrebljavate tijekom igre.

Zaigrajmo

Igranje digitalne igre

Možete igrati igru koju ste preuzeli putem ikone

PlayStation Store .

Primit ćete obavijest kada se dovrši preuzimanje i kada je igra spremna.

Odaberite igru s početnog zaslona Igre.

- Za kupnju i preuzimanje igara potrebno je povezati konzolu s internetom i prijaviti se u svoj račun.
- Za PlayStation™Network i trgovinu PlayStation Store vrijede odredbe upotrebe te ograničenja na temelju države i jezika. Korisnici snose troškove internetske usluge. Za određene sadržaje i/ili usluge plaća se naknada. Korisnici moraju imati najmanje 7 godina, a svi korisnici mlađi od 18 godina moraju imati suglasnost roditelja. Mogu se primjenjivati dodatna dobna ograničenja. Dostupnost usluge nije zajamčena. Značajke na mreži za specifične igre mogu se povući nakon obavijesti u razumnom vremenu – playstation.com/gameservers. Primjenjuju se cjelovite odredbe: uvjeti usluge PSN na web-mjestu playstation.com/legal/.

Igranje igre s diska

(Samo za konzole koje imaju pričvršćen diskovni pogon)

Umetnite disk.

Počet će se instalirati podaci igre, a primit ćete obavijest kad je igra spremna.

Odaberite igru s početne stranice igara.

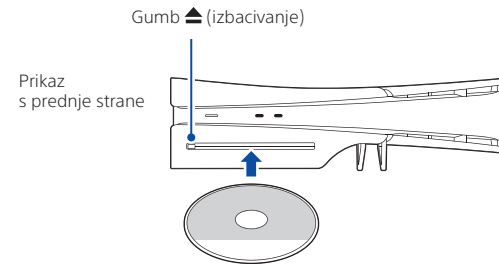

Izbacivanje diska

Pritisnite gumb ▲ (izbacivanje) kako biste izbacili disk.

Upotreba upravljača

Napunite upravljač

Dok je konzola PS5 uključena ili je u stanju mirovanja, upotrijebite USB kabel kako biste povezali upravljač s konzolom. Kada je konzola u stanju mirovanja, svjetlosna traka na upravljaču sporo treperi narančastom bojom. Nakon dovršetka punjenja svjetlosna se traka isključuje.

Za punjenje upravljača dok je konzola u stanju mirovanja idite na ikonu  **Settings (Postavke)** > **System (Sustav)** > **Power Saving (Ušteda energije)** > **Features Available in Rest Mode (Značajke dostupne u stanju mirovanja)** > **Supply Power to USB Ports (Napajanje USB priključnica)** i odaberite bilo koju opciju osim **Off (Isključeno)**.

Isključivanje mikrofona

Svaki put kada pritisnete gumb za isključivanje zvuka, vaš se mikروفон prebacuje između opcije isključeno (gumb svijetli) i uključeno (gumb ne svijetli).

Pritisnite i zadržite gumb za isključivanje zvuka kako biste isključili mikروفon, kao i izlaz za zvuk na zvučnicima upravljača i televizoru. Ponovno pritisnite gumb za isključivanje zvuka kako biste se vratili u početno stanje.

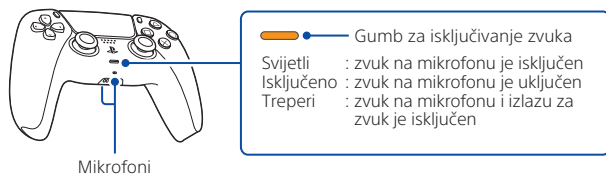

Upotreba više upravljača

Možete upotrebljavati do 4 upravljača istovremeno. Pritisnite gumb  (PS) kako biste dodijelili brojeve upravljačima. U skladu s tim uključuje se svjetlo za indikator igrača. Brojevi se dodjeljuju po redu počevši od 1, a broj svojeg upravljača možete odrediti po broju svjetala koja se upale.

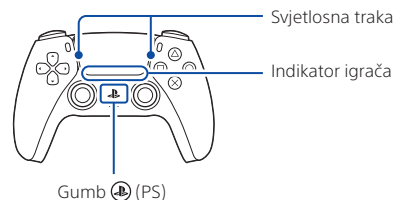

- Pri prvoj upotrebi morat ćete upariti svoj upravljač (stranica 16).
- Tijekom igranja igre za konzolu PS4 svjetlosna traka vašeg upravljača svijetlit će plavom, zelenom ili ružičastom bojom, ovisno o redoslijedu kojim je povezan upravljač. Ovo je odvojeno od indikatora igrača.

Uključivanje konzole PS5 s pomoću upravljača

Pritisnite gumb  (PS) na upravljaču za kojega je dovršeno uparivanje kako biste uključili svoju konzolu PS5.

Isključivanje



Oprez

Iskopčajte kabel za napajanje izmjeničnom strujom iz električne utičnice tek kada se indikator napajanja isključi. Ako ga iskopčate dok indikator napajanja svijetli ili treperi, podaci bi se mogli izgubiti ili oštetiti, a mogli biste oštetiti i konzolu.

Postavljanje konzole u stanje mirovanja

Način rada za uštedu energije na vašoj konzoli PS5 naziva se stanje mirovanja. Možete puniti svoj upravljač putem USB priključnica na konzoli, automatski ažurirati softver sustava i zaustaviti igru ili aplikaciju dok je konzola isključena. Za više informacija o tome koje su postavke za stanje mirovanja optimalne za vas pogledajte User's Guide (Upute za upotrebu) (stranica 24).

Za upotrebu nekih značajki morat ćete omogućiti njihove postavke. Odaberite gumb  **Settings (Postavke) > System (Sustav) > Power Saving (Ušteda energije) > Features Available in Rest Mode (Značajke dostupne u stanju mirovanja).**

Odaberite gumb  **Power (Napajanje)** u kontrolnom centru, a zatim odaberite **Enter Rest Mode (Pokretanje stanja mirovanja)**. Indikator napajanja treperi bijelom bojom, a zatim počinje svijetliti narančasto. Kako biste izašli iz stanja mirovanja, pritisnite gumb  (PS).

Potpuno isključivanje konzole

U kontrolnom centru odaberite ikonu  **Power (Napajanje)**, a zatim **Turn Off PS5 (Isključivanje konzole PS5)**. Indikator napajanja treperi bijelom bojom, a konzola se zatim isključuje.

Indikator napajanja

Bijelo	Konzola je uključena.
Narančasto	Konzola je u stanju mirovanja.
Isključeno	Dodatne informacije

Dodatne informacije

Upute o sigurnosti

Saznajte kako sigurno upotrebljavati konzolu PS5 uz priložene Upute o sigurnosti. Ovaj tiskani priručnik sadrži i uvjete jamstva proizvoda i informacije o specifikacijama. Obavezno ih pročitajte prije upotrebe konzole.

User's Guide (Upute za upotrebu)

Saznajte što sve može vaša konzola PS5. Saznajte kako konfigurirati postavke i kako upotrijebiti svaku funkciju. Na početnom zaslonu konzole PS5 idite na ikonu  Settings (Postavke) > User's Guide, Health and Safety, and Other Information (Upute za upotrebu, Zdravlje i sigurnost i Ostale informacije) > User's Guide (Upute za upotrebu).

Internetska služba za korisnike

Informacije o podršci, poput postupnog rješavanja problema i često postavljanih pitanja, potražite na playstation.com/help/.



"PS", "PlayStation", "PSS", "PS5", "PS4", "DualSense" i "PlayStation Shapes Logo" registrirane su trgovačke marke ili trgovačke marke tvrtke Sony Interactive Entertainment Inc. "SONY" i "PS" registrirane su trgovačke marke ili trgovačke marke tvrtke Sony Group Corporation.

The terms HDMI, HDMI High-Definition Multimedia Interface, HDMI Trade dress and the HDMI Logos are trademarks or registered trademarks of HDMI Licensing Administrator, Inc. USB-IF SuperSpeed USB Trident logo is a registered trademark of USB Implementers Forum, Inc.

USB Type-C® and USB-C® are registered trademarks of USB Implementers Forum. Wi-Fi® is a registered trademark of Wi-Fi Alliance®.

Oblik i tehničke karakteristike mogu se mijenjati bez prethodne najave.

Informacije o funkcijama sustava i slike objavljene u ovom dokumentu mogu se razlikovati za vašu konzolu, ovisno o trenutnoj verziji softvera sustava. Osim toga, ilustracije i slike zaslona iz ovog priručnika mogu se razlikovati od stvarnog proizvoda.

Informacije navedene u ovom priručniku mogu se mijenjati bez prethodne najave.

Să începem

1 Introduceți picioarele suportului orizontal în orificiul canelurilor consolei PlayStation®5.

Întotdeauna atașați picioarele consolei PS5® înainte de utilizare. Așezați consola pe o lavetă moale așezată deasupra unei suprafețe nivelate înainte de a atașa picioarele.

Consolă cu unitate de disc instalată

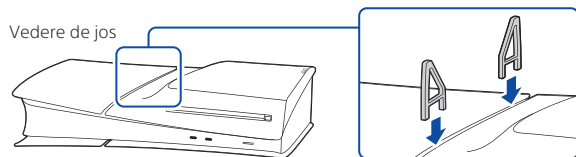

Consolă fără unitate de disc instalată

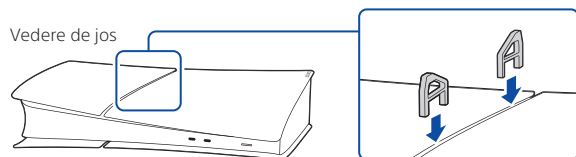

Dacă vreți să configurați consola PS5 în poziție verticală, va trebui să utilizați suportul vertical (vândut separat).

2 Conectați cablul HDMI și cablul de alimentare cu c.a.

Folosiți cablurile incluse.
Înainte de a conecta cablul de alimentare cu c.a. la priză, faceți toate celelalte conexiuni.

Următoarele ilustrații prezintă consola cu unitatea de disc instalată.

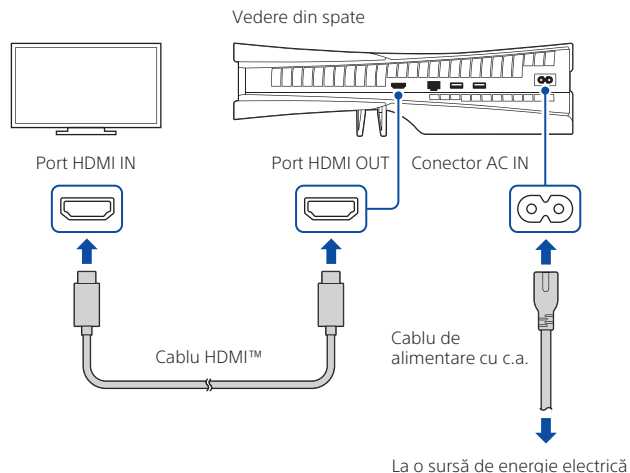

3 Conectați cablul LAN.

Pentru a realiza o conexiune cu fir la internet, folosiți un cablu LAN (neinclus). Dacă preferați să folosiți o conexiune Wi-Fi®, nu conectați un cablu LAN și treceți la următorul pas.

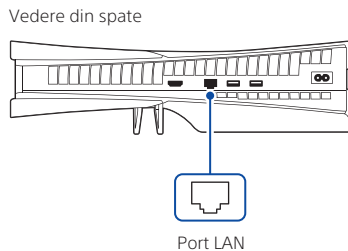

4 Porniți televizorul și setați intrarea la HDMI.

5 Porniți consola PS5 apăsând pe butonul (alimentare).

Indicatorul de alimentare luminează intermitent în albastru, iar apoi devine alb.

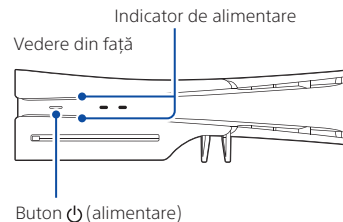

Dacă nu folosiți consola timp de 60 secunde după ce o deschideți, cititorul de ecran se activează. Puteți asculta textul de pe ecran și alte informații importante citite cu voce tare, pentru a vă ajuta să faceți ceea ce doriți. Cititorul de ecran este disponibil numai în anumite limbi.

6 Conectați controlerul fără fir DualSense® la consolă și apăsați butonul (PS).

Pentru a asocia controlerul, conectați-l cu un cablu USB la portul USB de pe consolă. Controlerul pornește când apăsați butonul (PS).

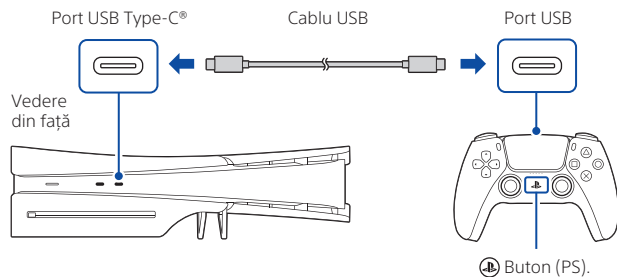

7 Personalizați-l.

Aproape ați terminat! Urmăriți instrucțiunile de pe ecran pentru a finaliza configurarea inițială.

- Configurarea contului
Creați un cont nou sau conectați-vă cu un cont existent. Conectându-vă cu un cont existent, puteți accesa abonamentul PlayStation®Plus și vă puteți vedea prietenii, trofee și alte informații despre cont.
- Transferul datelor de pe altă consolă
Dacă aveți o consolă PlayStation®4 sau altă consolă PS5, puteți transfera date pe noua consolă conectându-vă cu un cont existent.

Veți ști că s-a finalizat configurarea atunci când pe ecran apare mesajul **Bun venit la PlayStation 5**.

Consola PS5 va fi utilizată de un copil? Consultați și „Setări de control parental” (pagina 29).

- Opțiunile de configurare pe care le vedeți sunt personalizate în funcție de necesitățile dvs., pe baza informațiilor precum mediul rețelei și contul la care sunteți conectat.
- Puteți modifica orice setare selectând **Setări** din ecranul principal.

Setări de control parental

Poți gestiona setările pentru copiii care utilizează consola PS5. Setările de control parental îți permit să setezi restricții asupra jocurilor pe care copiii le pot juca, când și cât timp se joacă, dacă pot sau nu să converseze și multe altele.

Fiecare adult (😊) și fiecare copil (👶) va trebui să aibă cont individual separat. Atunci când creezi un cont pentru un copil, acesta este asociat automat cu contul tău, creând astfel o familie. Poți seta controale parentale numai pentru copiii din familia ta.

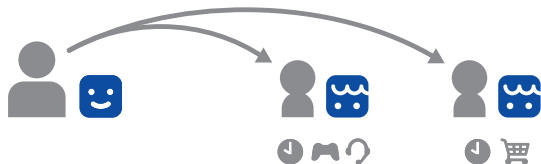

Pentru consola PS5 poți utiliza un cont existent, precum cel pe care l-ai creat pe o consolă PS4. Familia și setările pentru controalele parentale se vor transfera pe consola ta PS5.

Crearea unui cont pentru un copil

Poți să creezi un cont pentru copil și să setezi controalele parentale în același timp. Apasă butonul (PS) pentru a deschide centrul de control. Selectează fotografia de profil, apoi selectează **Comutare utilizator**. Din ecranul de selectare a utilizatorului, selectează **Adăugare utilizator** pentru a crea un cont.

Revizuirea și modificarea setărilor de control parental

Îți recomandăm să verifici în mod regulat controalele parentale pentru copil. Le poți revizui sau actualiza selectând **Setări** > **Familie și setări de control parental** de pe ecranul principal.

Setări de control parental





Pictogramele pentru evaluarea jocurilor

Fiecare joc vine cu o pictogramă pentru evaluarea jocului care te ajută să determini dacă jocul este adecvat pentru vârsta copilului.

Europa, Africa și India

Vârsta jucătorului	Vârsta de cel puțin 3 ani	Vârsta de cel puțin 7 ani	Vârsta de cel puțin 12 ani	Vârsta de cel puțin 16 ani	Vârsta de cel puțin 18 ani
Clasificări în funcție de vârstă					

Germania

Vârsta jucătorului	Vârsta de cel puțin 0 ani	Vârsta de cel puțin 6 ani	Vârsta de cel puțin 12 ani	Vârsta de cel puțin 16 ani	Vârsta de cel puțin 18 ani
Clasificări în funcție de vârstă					

Află mai multe despre funcțiile de control parental și configurarea din Ghidul utilizatorului (pagina 36).

Ce se vede pe ecran

Ecranul principal

De pe ecranul principal poți accesa două tipuri de conținut: jocuri sau fișiere media.

Pe pagina de pornire a jocurilor vei găsi jocurile tale, PlayStation™Store și alte aplicații asociate jocurilor.

Pe pagina de pornire media, vei găsi muzică, videoclipuri și alte aplicații neasociate jocurilor.

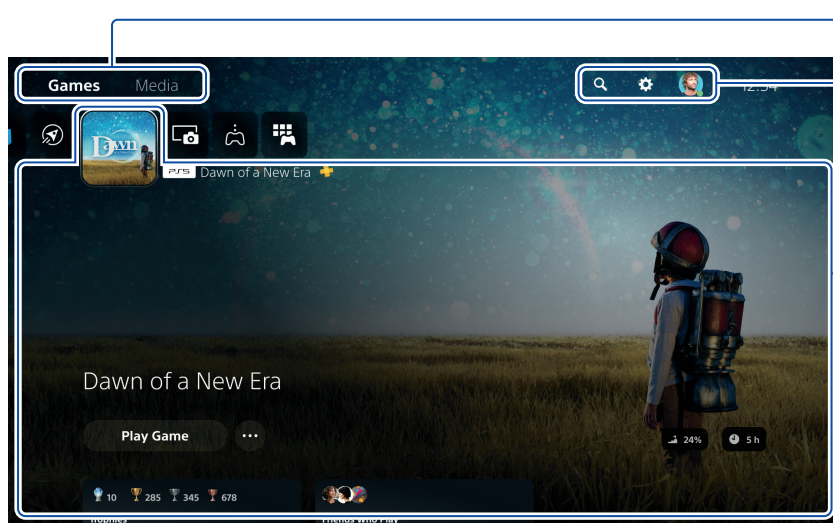



Comutarea ecranelor principale

Comută între jocuri și fișiere media.

Efectuează căutări, modifică-ți setările și editează-ți profilul.

Hub

Află mai multe despre jocul sau despre aplicația pe care ai selectat-o și găsește informații asociate.

- Pe consola PS5, butonul  confirmă elementele selectate.
- Pentru a reveni la ecranul principal în timp ce jocul sau aplicația este în funcțiune, selectează **Acasă**  din centrul de control sau apasă și ține apăsat butonul  (PS) pe controller.

Centrul de control

Apasă butonul (PS) pentru a deschide centrul de control.

Poți accesa o varietate de caracteristici fără să părăsești jocul sau aplicația.



Carduri

Cardurile îți arată funcții și activități asociate jocurilor și aplicațiilor care sunt disponibile în funcție de ceea ce faci în acel moment. Alege un card pentru a afla mai multe sau treci la următorul card.

Comenzi

Selectează **Acasă** 🏠 pentru a reveni la ecranul principal și selectează **Alimentare** ⏻ pentru a opri consola PS5. Tot aici poți alege și alte funcții de bază.

Obține acces rapid la funcțiile și setările pe care le folosești cel mai des în timpul jocurilor.

Să jucăm

Joacă un joc digital

Poți juca un joc pe care l-ai descărcat de pe **PlayStation Store**.

Vei primi o notificare atunci când jocul este descărcat și poate fi jucat.

Selectează jocul de pe pagina de pornire a jocurilor tale.

- Pentru a achiziționa și descărca jocuri, va trebui să conectezi consola la internet și să te conectezi la contul tău.
- PlayStation™ Network și PlayStation Store se află sub rezerva termenilor de utilizare, precum și a restricțiilor specifice fiecărei țări și a restricțiilor de limbă. Utilizatorii sunt responsabili pentru plata taxelor serviciilor de internet. Pentru un anumit conținut și/sau servicii se aplică taxe. Utilizatorii trebuie să aibă cel puțin 7 ani, iar cei sub 18 ani necesită acordul părinților. Se pot aplica restricții suplimentare referitoare la vârstă. Disponibilitatea serviciului nu este garantată. Este posibil ca, în cazul anumitor jocuri, să se retragă caracteristicile online, după o notificare prealabilă rezonabilă - playstation.com/gameservers. Se aplică termenii complete: termenii serviciului PSN de la adresa playstation.com/legal/.

Joacă un joc de pe disc

(Numai pentru consolele cu o unitate de disc instalată)

Introdu discul.

Datele din joc vor începe să se instaleze și vei primi o notificare când jocul este gata să fie jucat.

Selectează jocul din ecranul principal al jocurilor.

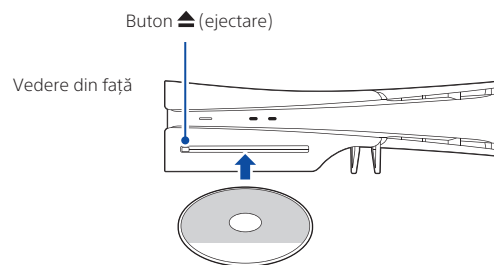

Scoaterea discului

Apasă butonul ▲ (ejectare) pentru a scoate discul.

Utilizarea controlerului

Încărcarea controlerului

Atunci când consola PS5 este pornită sau se află în modul de repaus, folosește un cablu USB pentru a-ți conecta controlerul la consolă. Atunci când consola este în modul de repaus, bara luminoasă de pe controler se aprinde intermitent lent în portocaliu. După finalizarea încărcării, bara luminoasă se stinge.

Pentru încărcarea controlerului atunci când consola este în modul de repaus, accesează **Setări** ⚙️ > **Sistem** > **Economisire energie** > **Caracteristici disponibile în modul de repaus** > **Alimentare cu energie pentru porturile USB**, și selectează altă opțiune decât **Dezactivat**.

Dezactivarea sunetului microfonului

De fiecare dată când apeși butonul de dezactivare sunet, microfonul comută între sunet dezactivat (buton apăs) și sunet activat (buton stins).

Apasă și ține apăsat butonul de dezactivare sunet pentru a dezactiva sunetul microfonului și pentru a dezactiva ieșirea de sunet de la difuzoarele de pe controler și de pe televizor. Apasă din nou butonul de dezactivare sunet pentru a reveni la starea inițială.

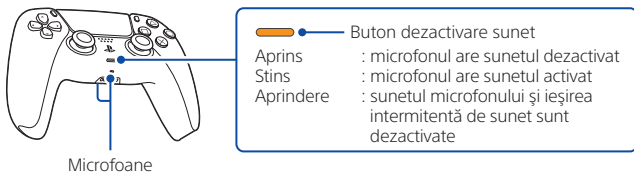

Utilizarea mai multor controlere

Poți utiliza până la 4 controlere în același timp. Apasă butonul (PS) pentru a alocă numere controlerelor. Indicatorul de jucător se aprinde în mod corespunzător. Numerele sunt alocate în ordine de la 1, și poți determina numărul controlerului în funcție de numărul de lumini care se aprind.

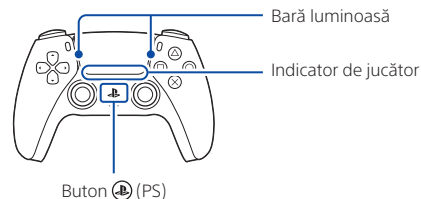

- Va trebui să îți asociezi controlerul atunci când îl utilizezi pentru prima dată (pagina 28).
- Când joci un joc PS4, bara luminoasă a controlerului se aprinde în albastru, roșu, verde sau roz, în funcție de ordinea în care este conectat controlerul. Acest lucru este separat de indicatorul de jucător.

Pornirea consolei PS5 cu un controler

Apasă butonul (PS) de pe un controler care s-a asociat deja, pentru a porni consola PS5.

Închiderea



Atenție

Deconectează cablul de alimentare cu c.a. de la priza electrică doar atunci când indicatorul de alimentare este stins. Dacă îl deconectezi în timp ce indicatorul de alimentare este aprins sau luminează intermitent, datele pot fi pierdute sau se pot corupe și poți deteriora consola.

Setarea consolei în modul de repaus

Modul de economisire a energiei al consolei PS5 se numește mod de repaus. Atunci când consola este oprită, poți face lucruri precum încărcarea controlerului prin porturile USB ale consolei, actualizarea automată a software-ului de sistem și menținerea jocului sau a aplicației în așteptare. Pentru a afla care setări ale modului de repaus sunt cele optime pentru tine, consultă Ghidul utilizatorului (pagina 36).

Pentru a putea utiliza unele funcții va trebui să le activezi setările. Accesează **Setări**  > **Sistem** > **Economisire energie** > **Caracteristici disponibile în modul de repaus**.

Selectează **Alimentare**  din centrul de control, apoi selectează **Intrare în modul de repaus**. Indicatorul de alimentare luminează intermitent în alb, apoi devine portocaliu. Pentru a părăsi modul de repaus, apasă butonul  (PS).

Oprirea completă a consolei

Selectează **Alimentare**  din centrul de control, apoi selectează **Oprire PS5**. Indicatorul de alimentare luminează intermitent în alb, iar apoi consola se oprește.

Indicator de alimentare

Alb	Consola este pornită.
Portocaliu	Consola se află în modul de repaus.
Stins	Consola este oprită.

Informații suplimentare

Ghidul de siguranță

Află cum să utilizezi consola PS5 în condiții de siguranță, cu Ghidul de siguranță furnizat. Acest manual tipărit conține și termenii garanției produsului, precum și informații despre specificații. Asigură-te că îl citești înainte de utilizarea consolei.

Ghidul utilizatorului

Descoperă tot ceea ce poate face consola PS5. Află cum poți configura setările și cum poți utiliza fiecare funcție. De pe ecranul principal al consolei PS5, accesează **Setări**  > **Ghidul utilizatorului, Sănătate și siguranță și alte informații** > **Ghidul utilizatorului**.

Site-ul web pentru asistența clienților

Găsește informații de asistență online, precum depanare pas cu pas și întrebări frecvente, vizitând playstation.com/help/.



„PS”, „PlayStation”, „PS5”, „PS4”, „DualSense” și „PlayStation Shapes Logo” sunt mărci comerciale înregistrate sau mărci comerciale ale Sony Interactive Entertainment Inc. „SONY” și  sunt mărci comerciale înregistrate sau mărci comerciale ale Sony Group Corporation.

The terms HDMI, HDMI High-Definition Multimedia Interface, HDMI Trade dress and the HDMI Logos are trademarks or registered trademarks of HDMI Licensing Administrator, Inc. USB-IF SuperSpeed USB Trident logo is a registered trademark of USB Implementers Forum, Inc.

USB Type-C® and USB-C® are registered trademarks of USB Implementers Forum. Wi-Fi® is a registered trademark of Wi-Fi Alliance®.

Designul și specificațiile pot fi modificate fără notificare.

Informațiile referitoare la funcționalitatea sistemului și imaginile publicate în acest document pot diferi de cele pentru consola ta, în funcție de versiunea în uz a software-ului de sistem. De asemenea, ilustrațiile și imaginile ecranului utilizate în acest ghid pot diferi de produsul efectiv.

Informațiile din acest ghid sunt supuse modificărilor fără înștiințare.

Да започваме

1 Поставете краката на хоризонталната стойка в отвора в жлебовете на конзолата PlayStation®5.

Винаги прикрепяйте краката към конзолата PS5® преди употреба. За да прикрепите краката, поставете конзолата върху мека кърпа, разгъната върху равна повърхност.

Конзола с монтирано оптично устройство

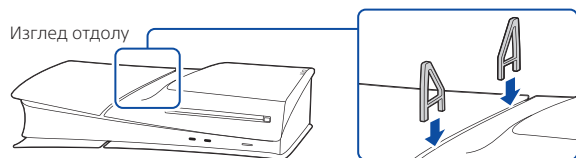

Конзола без монтирано оптично устройство

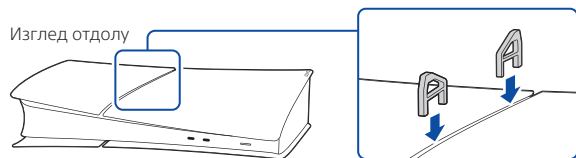

Ако искате да поставите конзолата PS5 във вертикално положение, ще трябва да използвате вертикалната стойка (продава се отделно).

2 Свържете HDMI кабела и AC захранващия кабел.

Използвайте предоставените кабели. Изпълнете всички връзки, преди да включите AC захранващия кабел към електрозахранването.

Всички илюстрации по-долу показват конзолата с монтирано оптично устройство.

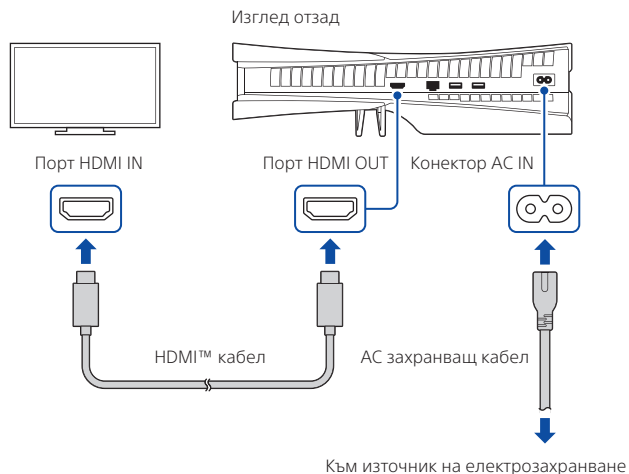

3 Свържете LAN кабела.

За кабелна връзка с интернет използвайте LAN кабел (не е включен). В случай че ще използвате Wi-Fi®, не свързвайте LAN кабел и преминете към следващата стъпка.

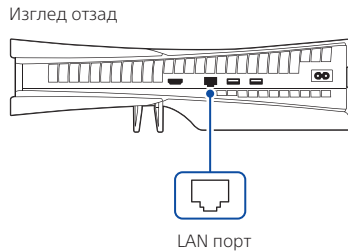

4 Включете телевизора и изберете настройката HDMI.

5 Включете конзолата PS5, като натиснете бутона (захранване).

Индикаторът за захранване премигва в синьо, след което преминава в бяло.

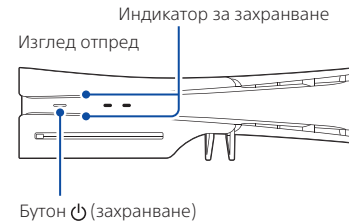

Ако не използвате конзолата в продължение на 60 секунди, след като я включите, се активира екранният четец. Можете да слушате текст на екрана и друга важна информация, прочетена на глас, което ще ви помогне да постигнете това, което искате да направите. Екранният четец е налице само на определени езици.

6 Свържете безжичния контролер DualSense® към конзолата и натиснете бутона (PS).

За да свържете контролера, свържете го с USB кабел към USB порта на конзолата. Когато натиснете (PS), контролерът се включва.

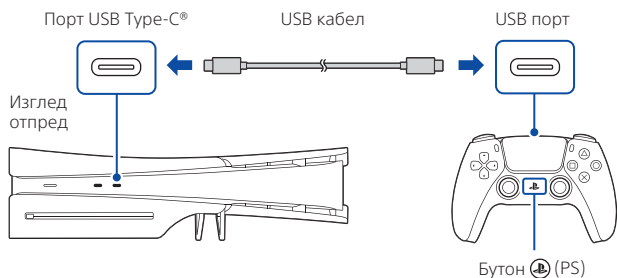

7 Направете го по свой вкус.

Почти приключихте! За да продължите с настройката, следвайте инструкциите на екрана.

- **Настройване на акаунта**
Създайте нов акаунт или влезте със съществуващ. Като влезете със съществуващия си акаунт, можете да получите достъп до абонамента PlayStation®Plus, както и до приятели, трофеи и друга информация за акаунта.
- **Прехвърляне на данни от друга конзола**
Ако имате PlayStation®4 конзола или друга конзола PS5, можете да прехвърлите данни към новата си конзола, като влезете със съществуващ акаунт.

Ще разберете, че настройката е завършена, когато на екрана видите **Welcome to PlayStation 5 (Добре дошли в PlayStation 5)**.

Конзолата PS5 ще се използва ли от дете? Вижте също „Родителски контроли“ (страница 41).

- Опциите за настройка, които виждате, са съобразени с нуждите ви въз основа на информацията като мрежовата ви среда и акаунта, който използвате.
- Можете да се върнете и да промените всяка от настройките си, като изберете **Settings (Настройки)** ⚙️ от началния екран.

Родителски контроли

Можете да управлявате настройките за деца, които използват PS5 конзолата ви. Родителският контрол ви позволява да поставите ограничения какви игри могат да играят децата, кога и колко дълго могат да играят, дали могат да чатят и други.

Всеки възрастен (😊) и дете (👶) ще се нуждаят от собствени отделни акаунти. Когато създавате акаунт за дете, той автоматично се свързва с вашия, създавайки семейство. Можете да задавате родителски контроли само за деца от семейството ви.

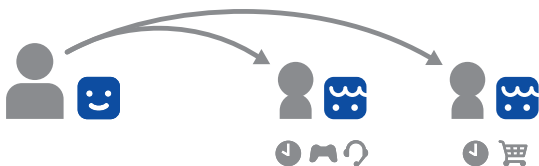

За вашата конзола PS5 можете да използвате съществуващ акаунт, например този, който сте създали на PS4 конзола. Настройките на семейните и родителските контроли ще се прехвърлят към вашата конзола PS5.

Създаване на акаунт за дете

Можете едновременно да създадете акаунт за дете и да зададете родителски контроли. Натиснете бутона (PS), за да отворите центъра за управление. Изберете профилната си снимка, след което изберете **Switch User (Превключване на потребителя)**. От екрана за избор на потребител изберете **Add User (Добавяне на потребител)**, за да създадете акаунт.





Преглед и промяна на настройките на родителските контроли

Препоръчваме да проверявате редовно родителските контроли за детето си. Можете да ги прегледате или актуализирате, като изберете **Settings (Настройки)** > **Family and Parental Controls (Семейни и родителски контроли)** от началния екран.

Икони за възрастово ограничение на игрите

За всяка игра е налице икона за възрастово ограничение, чрез която можете да определите дали е подходяща за възрастта на детето.

Европа, Африка и Индия

Възраст на играча	Над 3 год.	Над 7 год.	Над 12 год.	Над 16 год.	Над 18 год.
Възрастово ограничение за игра					

Германия

Възраст на играча	Над 0 год.	Над 6 год.	Над 12 год.	Над 16 год.	Над 18 год.
Възрастово ограничение за игра					

Научете повече за функциите и настройките на родителските контроли в User's Guide (Ръководство за потребителя) (страница 48).

Информация на екрана

Начален екран

От началния екран можете да преминете към два типа съдържание: игри или мултимедийно съдържание. На началния екран „Игри“ ще намерите игрите си, PlayStation™Store и други свързани с игрите приложения. На началния екран „Мултимедия“ ще намерите музика, видеоклипове и други приложения, които не са свързани с игри.

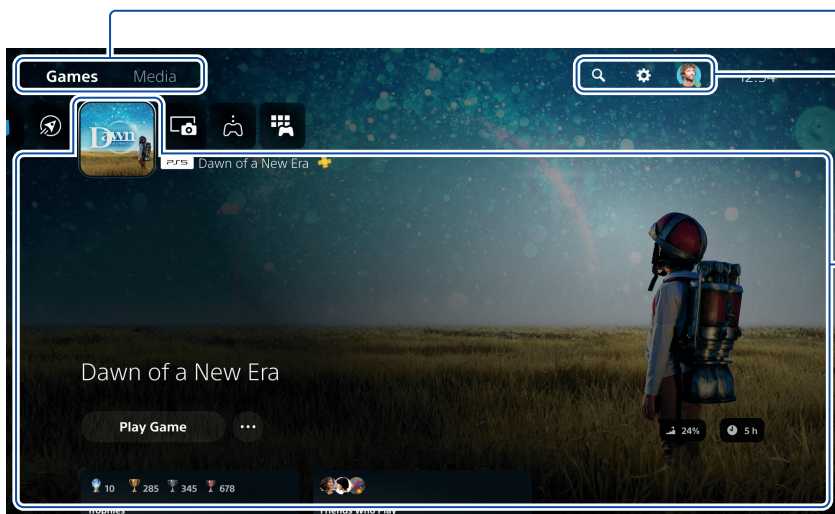

Превключване между началните екрани

Превключете между игри и мултимедийно съдържание.

Търсете, променяйте настройките си и редактирайте профила си.

Хъб

Научете повече за избраната от вас игра или приложение и намерете свързана с тях информация.

- Бутонът (X) на конзолата PS5 потвърждава избрания елемент.
- За да се върнете на началния екран, докато играете или използвате приложение, изберете Home (Начало) (PS) от центъра за управление или натиснете и задръжте бутона (PS) на контролера ви.

Център за управление

Натиснете бутона (PS), за да отворите центъра за управление.

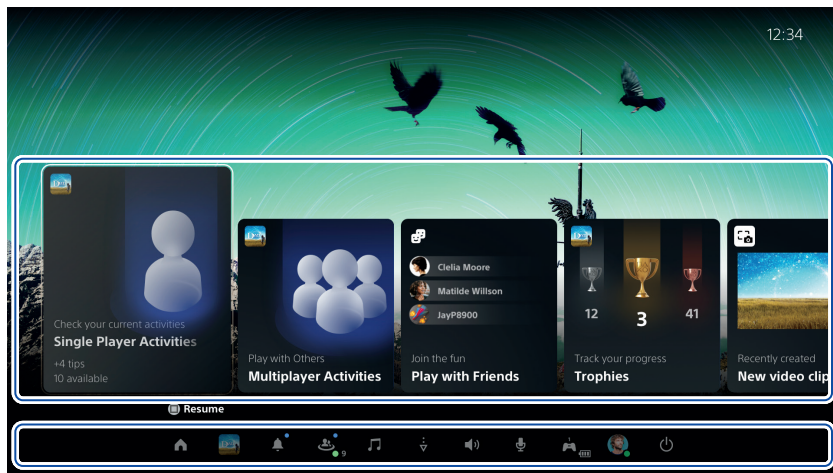

Можете да получите достъп до различни функции, без да напускате играта или приложението.



Карти

Картите показват функции и дейности, свързани с наличните игри и приложения, в зависимост от това, което правите в този момент. Изберете карта, за да научите повече, или преминете към следващата карта.

Контроли

Изберете **Home (Начало)**  за да се върнете на началния екран, и след това **Power (Захранване)**  за да изключите конзолата PS5. Тук можете да изпълнявате също други основни функции.

Получете бърз достъп до функциите и настройките, които използвате най-често по време на игра.

Нека играем

Дигитална игра

Можете да играете игра, която сте свалили от **PlayStation Store** .

Ще получите известие, когато играта е свалена и сте готови за игра.

Изберете играта от началния екран „Игри“.

- За да купувате и сваляте игри, трябва да свържете конзолата към интернет и да влезете в акаунта си.
- PlayStation™Network и PlayStation Store са предмет на условията за ползване и ограниченията за държавата и езика. Таксите за връзка с интернет се плащат от потребителите. За някои видове съдържание и/или услуги се изисква таксуване. Потребителите трябва да имат навършени 7 години, а за тези на възраст под 18 г. се изисква разрешение от родителите. Може да са в сила допълнителни възрастови ограничения. Наличността на услугата не е гарантирана. Онлайн функциите на конкретни игри може да бъдат оттеглени с основателно предизвестие – playstation.com/gameservers. В сила са всички условия. Общите условия на PSN са достъпни на адрес playstation.com/legal/.

Игра от диск

(Само за конзоли с инсталирано оптично устройство)

Поставете диска.

Данните за играта ще започнат да се инсталират и ще получите известие, когато играта е готова.

Изберете играта от началния екран на игрите.

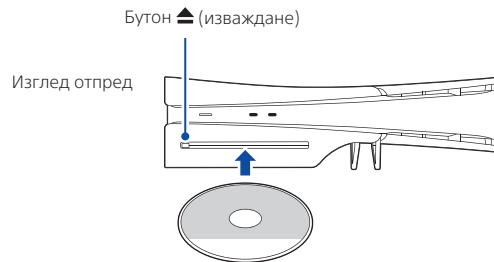

Изваждане на диска

Натиснете бутона ▲ (изваждане), за да извадите диска.

Използване на контролера

Зареждане на контролера

При включена конзола PS5 или в режим почивка използвайте USB кабел, за да свържете контролера към конзолата. Когато конзолата е в режим почивка, светлинната лента на контролера премигва бавно в оранжево. Когато зареждането завърши, светлинната лента угасва.

За да заредите контролера, докато конзолата ви е в режим почивка, отворете Settings (Настройки) > System (Система) > Power Saving (Пестене на енергия) > Features Available in Rest Mode (Функции, налични в режим почивка) > Supply Power to USB Ports (Захранване към USB портове), и изберете опция, различна от Off (Изкл.).

Заглушаване на микрофона

Всеки път, когато натиснете бутона за без звук, вашият микрофон се превключва между изключен (бутонът свети) и включен (бутонът не свети).

Натиснете и задръжте бутона за без звук, за да изключите вашия микрофон и звука, идващ от слушалките на контролера и телевизора. Натиснете отново бутона за без звук, за да се върнете в първоначалното състояние.

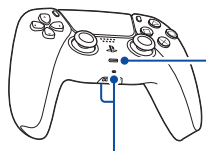

Микрофони

— Бутон за без звук

Свети	: Микрофонът е изключен
Изключен	: Микрофонът е включен
Мига	: Микрофонът и изходящият звук са изключени

Използване на няколко контролера

Можете да използвате до 4 контролера едновременно. Натиснете бутона (PS), за да зададете числа на контролерите. Индикаторите на играчите съответно светват. Числата се задават поред от 1 и можете да определите номера на контролера си по броя на светлините, които се включват.



- Трябва да сдвоите контролера си, когато го използвате за първи път (страница 40).
- Когато играете PS4 игра, светлинната лента на контролера свети в синьо, червено, зелено или розово в зависимост от реда, в който е свързан контролерът. Това е отделно от индикатора на играча.

Включване на конзолата PS5 с контролер

Натиснете бутона (PS) на контролера, за който сдвояването е завършило, за да включите конзолата PS5.

Изключване



Предупреждение

Изваждайте АС захранващия кабел от източника на електрозахранване само когато индикаторът за захранване е изключен. Ако го извадите, докато индикаторът за захранване свети или премигва, може да бъдат изгубени и повредени данни и е възможно да повредите конзолата си.

Поставяне на конзолата в режим почивка

Режимът за пестене на енергия на конзолата PS5 се нарича режим почивка. Можете да правите неща, като да зареждате контролера си през USB портовете на конзолата, автоматично да актуализирате софтуера на системата си и да държите играта или приложението си спрени, докато конзолата е в изключено състояние. За да разберете кои настройки за режим почивка са най-подходящи за вас, вижте User's Guide (Ръководство за потребителя) (страница 48).

За някои функции ще трябва да активирате съответните им настройки, за да ги използвате. Отворете **Settings (Настройки)**  > **System (Система)** > **Power Saving (Пестене на енергия)** > **Features Available in Rest Mode (Функции, налични в режим почивка)**.

Изберете **Power (Захранване)**  от центъра за управление и след това **Enter Rest Mode (Влизане в режим почивка)**. Индикаторът за захранване премигва в бяло, след което става оранжев. За да излезете от режима почивка, натиснете бутона  (PS)

Цялостно изключване на вашата конзола

Изберете **Power (Захранване)**  от центъра за управление и след това **Turn Off PS5 (Изключване на PS5)**. Индикаторът за захранване премигва в бяло, след което конзолата се изключва.

Индикатор за захранване

Бяло.	Конзолата е включена.
Оранжево.	Конзолата е в режим почивка.
Изкл.	Конзолата е изключена.

Допълнителна информация

Безопасност и поддръжка

Научете как да използвате конзолата PS5 безопасно с предоставения документ Безопасност и поддръжка. Това печатно ръководство съдържа също гаранционни условия за продукта и информация за спецификациите. Прочетете го, преди да използвате конзолата си.

User's Guide (Ръководство за потребителя)

Научете всички възможности на конзолата PS5. Научете как да конфигурирате настройки и как да използвате всяка функция. От началния екран на конзолата PS5 отворете **Settings (Настройки)** > **User's Guide, Health and Safety, and Other Information (Ръководство за потребителя, безопасност и здраве и друга информация)** > **User's Guide (Ръководство за потребителя)**.

Уебсайт за поддръжка на клиенти

Намерете информация за онлайн поддръжка, като поетапно отстраняване на неизправности и често задавани въпроси, като отворите playstation.com/help/.



“PS”, “PlayStation”, “PS5”, “PS5”, “PS4”, “DualSense” и “PlayStation Shapes Logo” са регистрирани търговски марки или търговски марки на Sony Interactive Entertainment Inc. “SONY” и “PS” са регистрирани търговски марки или търговски марки на Sony Group Corporation.

The terms HDMI, HDMI High-Definition Multimedia Interface, HDMI Trade dress and the HDMI Logos are trademarks or registered trademarks of HDMI Licensing Administrator, Inc.

USB-IF SuperSpeed USB Trident logo is a registered trademark of USB Implementers Forum, Inc.

USB Type-C® and USB-C® are registered trademarks of USB Implementers Forum.

Wi-Fi® is a registered trademark of Wi-Fi Alliance®.

Дизайнът и спецификациите могат да се променят без предизвестие.

Информацията за функционалността на системата и изображенията, публикувани в този документ, може да се различават от тези за вашата конзола, в зависимост от използваната версия на софтуера на системата. Също така илюстрациите и екранните изображения, използвани в това ръководство, може да се различават от реалния продукт.

Информацията в това ръководство подлежи на промяна без предизвестие.

Hajde da počnemo

1 Umetnite nožice horizontalnog postolja u otvor proreza na PlayStation®5 konzoli.

Obavezno postavite nožice pre korišćenja PS5® konzole. Stavite konzolu na meku tkaninu koju ste postavili na ravnu površinu pre nego što postavite nožice.

Konzola sa instaliranim disk drajvom

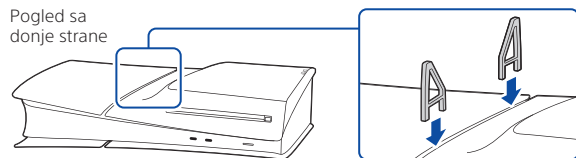

Konzola bez instaliranog disk drajva

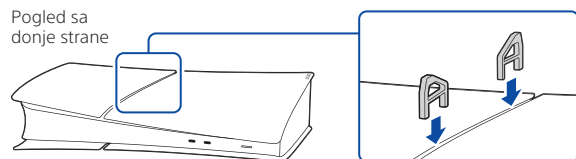

Potrebno vam je vertikalno postolje (prodaje se zasebno) ako PS5 konzolu želite da postavite u uspravan položaj.

2 Povežite HDMI kabl i kabl za napajanje naizmeničnom strujom.

Koristite isporučene kablove. Povežite sve kablove pre nego što priključite kabl za napajanje naizmeničnom strujom na izvor napajanja.

Na sledećim slikama je prikazana konzola sa instaliranim disk drajvom.

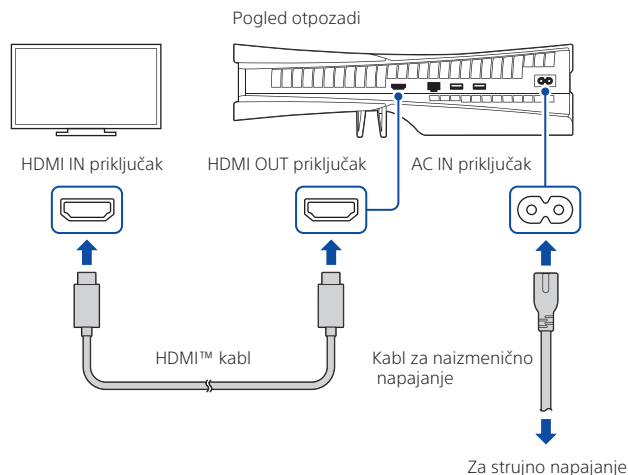

3 Povežite LAN kabl.

Za ožičenu internet vezu koristite LAN kabl (ne isporučuje se).
Ako nameravate da koristite Wi-Fi®, nemojte da povezujete LAN kabl i pređite na sledeći korak.

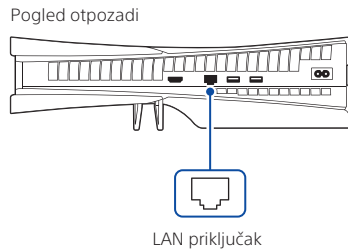

4 Uključite televizor i podesite ulaz na HDMI.

5 Uključite PS5 konzolu tako što ćete pritisnuti dugme (napajanje).

Indikator napajanja treperi plavo, a zatim počinje da svetli belo.

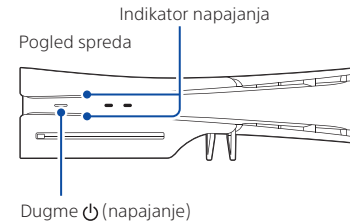

Ako ostavite konzolu da bude neaktivna 60 sekundi nakon što ste je uključili, čitač ekrana će se uključiti. Možete da slušate naglas pročitane tekst na ekranu i druge važne informacije koje će vam pomoći da postignete ono što ste želeli da obavite. Čitač ekrana je dostupan samo na određenim jezicima.

6 Povežite DualSense® bežični kontroler sa konzolom pa pritisnite dugme (PS).

Da biste uparili kontroler, povežite ga putem USB kabla sa priključkom USB na konzoli. Kada pritisnete dugme  (PS), kontroler će se uključiti.

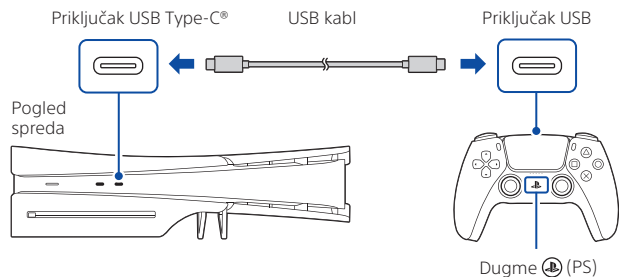

7 Prilagodite ga prema željama.

Skoro ste završili! Pratite uputstva na ekranu da biste dovršili početno podešavanje.

- Podesite nalog
Napravite novi nalog ili se prijavite sa nalogom koji ste već kreirali. Kada se prijavite sa svojim nalogom, imate pristup PlayStation®Plus pretplati, kao i prijateljima, trofejima i drugim informacijama.
- Prenos podataka sa druge konzole
Ako imate PlayStation®4 konzolu ili još jednu PS5 konzolu, podatke možete da prenesete na novu konzolu kada se prijavite sa postojećim nalogom.

Znaćete da je podešavanje dovršeno kada se na ekranu prikaže poruka **Welcome to PlayStation 5 (Dobro došli u PlayStation 5)**.

Da li će PS5 konzolu koristiti deca? Takođe pogledajte odeljak „Roditeljski nadzor“ (53 strana).

- Opcije podešavanja koje vidite prilagodene su vašim potrebama na osnovu informacija poput mrežnog okruženja i naloga sa kojim ste prijavljeni.
- Možete se vratiti i promeniti bilo koju postavku tako što ćete izabrati Settings (Postavke)  na početnom ekranu.

Roditeljski nadzor

Možete upravljati postavkama za decu koja koriste vašu PS5 konzolu. Roditeljski nadzor omogućava vam da postavite ograničenja za igre koje deca mogu da igraju, kada i koliko dugo mogu da igraju, da li mogu da časkaju uz korišćenje kamere, i još puno toga.

Za svaku odraslu osobu (😊) i dete (😡) biće potreban zaseban nalog. Kada napravite nalog za dete, on se automatski povezuje sa vašim nalogom, stvarajući porodicu. Možete da podesite roditeljski nadzor samo za decu u svojoj porodici.

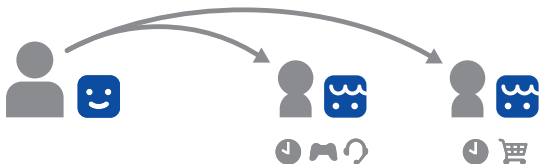

Možete da koristite postojeći nalog, poput onog koji ste kreirali na PS4 konzoli, i na PS5 konzoli. Vaše postavke porodičnog i roditeljskog nadzora će biti prenete na PS5 konzolu.

Kreiranje naloga za dete

Možete odjednom kreirati dečiji nalog i podesiti roditeljski nadzor.

Pritisnite dugme (PS) da biste otvorili kontrolni centar. Izaberite svoju profilnu sliku, a zatim izaberite opciju **Switch User (Promeni korisnika)**. Na ekranu za izbor korisnika, izaberite **Add User (Dodaj korisnika)** da biste kreirali nalog.

Pregled i izmena postavki roditeljskog nadzora

Preporučuje se da redovno proveravate dečiji roditeljski nadzor. Možete ga pregledati ili ažurirati tako što ćete odabrati **Settings (Postavke)** > **Family and Parental Controls (Porodični i roditeljski nadzor)** na početnom ekranu.

Ikone za ocenjivanje igara

Svaka igra nosi ikonu za ocenjivanje igre koja vam pomaže da utvrdite da li je igra primerena detetovom uzrastu.

Evropa, Afrika i Indija

Uzrast igrača	3 godine i iznad	7 godina i iznad	12 godina i iznad	16 godina i iznad	18 godina i iznad
Preporučeni uzrast					

Nemačkay

Uzrast igrača	0 godina i iznad	6 godina i iznad	12 godina i iznad	16 godina i iznad	18 godina i iznad
Preporučeni uzrast					

Saznajte više o karakteristikama i postavkama roditeljskog nadzora u Korisničkom vodiču (strana 60).

Šta je prikazano na ekranu

Početni ekran

Preko početnog ekrana možete da pristupite dvema vrstama sadržaja: igrama i medijskom sadržaju.

Na početnom ekranu za igre pronaći ćete svoje igre, prodavnicu PlayStation™Store i druge aplikacije povezane sa igrama.

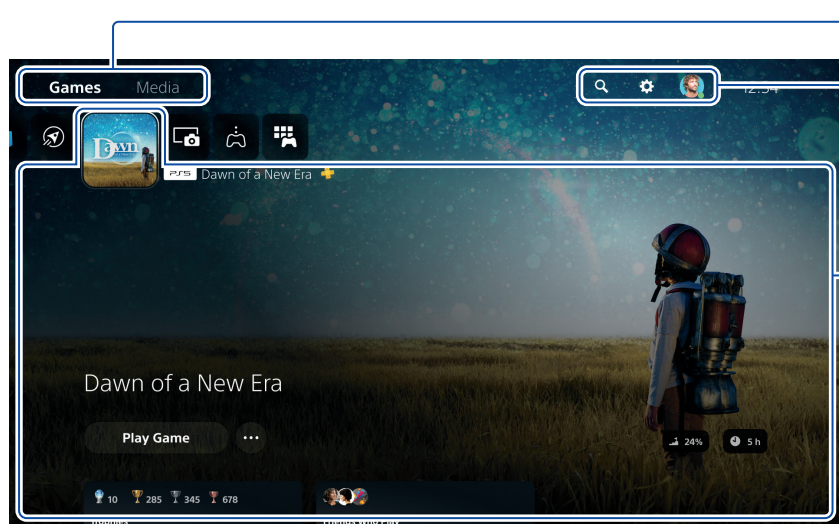

Na početnom ekranu za medije pronaći ćete muziku, video zapise i druge aplikacije nevezane za igre.



Prebacivanje između početnih ekrana
Prebacujte se između igara i medijskog sadržaja.

Pretražujte, menjajte svoje postavke i uređujte svoj profil.

Hab
Saznajte više o igri ili aplikaciji koju ste odabrali i pronađite vezane informacije.

- Na PS5 konzoli, dugme  služi za potvrdu izabranih stavki.
- Da biste se vratili na početni ekran kada ste pokrenuli igru ili aplikaciju, odaberite Home (Početak)  u centru kontrola ili pritisnite i držite dugme  (PS) na kontroleru.

Šta je prikazano na ekranu

Centar kontrola

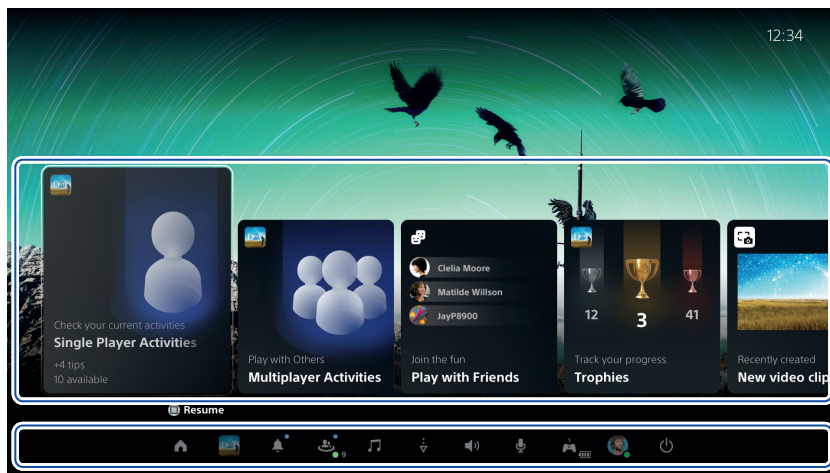

Pritisnite dugme  (PS) da biste otvorili centar kontrola.
Možete da pristupite nizu funkcija bez napuštanja igre ili aplikacije.



Kartice

Kartice vam prikazuju funkcije i aktivnosti u vezi sa igrama i aplikacijama koje su dostupne u zavisnosti od toga šta radite u tom trenutku. Izaberite karticu da biste saznali više ili pređite na sledeću karticu.

Kontrole

Odaberite **Home (Početak)**  za povratak na početni ekran i odaberite **Power (Napajanje)**  da biste isključili PS5 konzolu. Ovde takođe možete obaviti ostale osnovne funkcije.

Brzo pristupite funkcijama i postavkama koje najviše koristite tokom igranja.

Hajde da se igramo

Igranje digitalne igre

Možete igrati igru koju ste preuzeli iz prodavnice **PlayStation Store**.

Dobićete obaveštenje kada igra bude preuzeta i spremna za igranje.

Odaberite igru na početnom ekranu za igre.

- Kako biste kupili i preuzeli igre, potrebno je da povežete konzolu na internet i prijavite se u svoj nalog.
- Na PlayStation™Network i PlayStation Store primenjuju se uslovi korišćenja i ograničenja država i jezika. Korisnici snose troškove internet usluge. Za određene sadržaje i/ili usluge plaća se naknada. Korisnici moraju da imaju najmanje 7 godina, a korisnicima mlađim od 18 godina potrebna je saglasnost roditelja. Mogu se primenjivati dodatna starosna ograničenja. Dostupnost usluge se ne garantuje. Mrežne funkcije određenih igara mogu biti povučene nakon obaveštenja u razumnom vremenskom roku – playstation.com/gameservers. Primenuju se kompletni uslovi: [uslovi korišćenja PSN usluge na web lokaciji playstation.com/legal/](http://uslovi_korisčenja_PSN_usluge_na_web_lokaciji_playstation.com/legal/).

Igranje igre sa diska

(Samo za konzole sa postavljenim disk drajvom)

Ubacite disk.

Podaci igre će se instalirati i obavestiće vas se kad je igra spremna.

Izaberite igru na početnom ekranu igara.

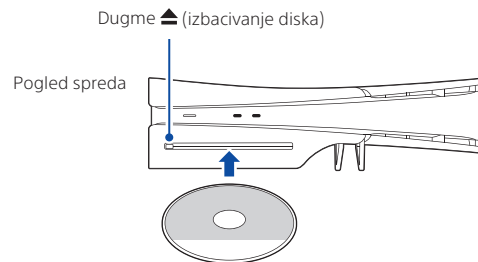

Izbacivanje diska

Pritisnite dugme ▲ (izbacivanje diska) da biste izbacili disk.

Korišćenje kontrolera

Punjenje kontrolera

Kada je PS5 konzola uključena ili u režimu odmaranja, povežite kontroler sa konzolom putem USB kabela.

Kada je konzola u režimu odmaranja, svetlosna traka na kontroleru sporo treperi narandžasto. Kada se punjenje dovrši, svetlosna traka će se isključiti.

Da biste napunili kontroler dok je konzola u režimu odmaranja, idite na **Settings (Postavke)** > **System (Sistem)** > **Power Saving (Ušteda energije)** > **Features Available in Rest Mode (Funkcije dostupne u režimu odmaranja)** > **Supply Power to USB Ports (Obezbedi napajanje priključcima USB)** i odaberite bilo koju opciju osim **Off (Isključeno)**.

Isključivanje zvuka mikrofona

Svaki put kada pritisnete dugme za isključivanje zvuka, mikrofon se prebacuje između isključenog (dugme svetli) i uključenog (dugme ne svetli).

Pritisnite i držite dugme za isključivanje zvuka da biste isključili zvuk na mikrofону, kao i izlaz za zvuk na zvučnicima kontrolera i televizoru. Ponovo pritisnite dugme za isključivanje zvuka da biste se vratili u prvobitno stanje.



Dugme za isključivanje zvuka

Svetli : Mikrofon je isključen
Isključeno : Mikrofon je uključen
Treperi : Mikrofon i zvučni izlaz su isključeni

Korišćenje više kontrolera

Možete odjednom koristiti do 4 kontrolera. Pritisnite dugme (PS) kako biste kontrolerima dodelili brojeve. Lampice indikatora igrača će se uključiti u skladu sa tim. Brojevi se dodeljuju redom počev od 1, tako da možete odrediti broj kontrolera prema broju lampica koje će se uključiti.

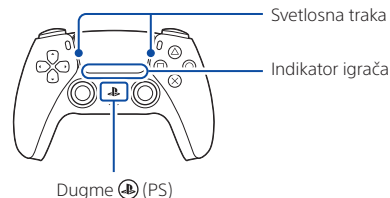

- Biće potrebno da uparite kontroler kada ga prvi put budete koristili (strana 52).
- Kada igrate igru za PS4, svetlosna traka na kontroleru svetli plavo, crveno, zeleno ili ružičasto, u zavisnosti od redosleda kojim je kontroler povezan. Ovo se razlikuje od indikatora igrača.

Uključivanje PS5 konzole pomoću kontrolera

Pritisnite dugme (PS) na kontroleru sa kojim je dovršeno uparivanje da biste uključili PS5 konzolu.

Isključivanje



Oprez

Isključite kabl za napajanje naizmjeničnom strujom iz strujnog napajanja tek kada se indikator napajanja isključi. Ako ga isključite dok indikator napajanja svetli ili treperi, podaci mogu biti izgubljeni ili oštećeni, a takođe možete oštetiti konzolu.

Stavljanje konzole u režim odmaranja

Režim za uštedu energije na PS5 konzoli zove se režim odmaranja. Možete obaviti stvari poput punjenja kontrolera preko priključaka USB na konzoli, automatskog ažuriranja sistemskog softvera i obustavljanja igre ili aplikacije dok je konzola isključena. Da biste saznali koja su podešavanja režima odmaranja optimalna za vas, pogledajte Korisnički vodič (strana 60).

Pojedine funkcije će zahtevati da omogućite njihove postavke kako biste mogli da ih koristite. Idite na **Settings (Postavke)**  > **System (Sistem)** > **Power Saving (Ušteda energije)** > **Features Available in Rest Mode (Funkcije dostupne u režimu odmaranja)**.

Odaberite **Power (Napajanje)**  u centru kontrola, a zatim odaberite **Enter Rest Mode (Pristupi režimu odmaranja)**. Indikator napajanja treperi belo, a zatim počinje da svetli narandžasto. Da biste izašli iz režima odmaranja, pritisnite dugme  (PS).

Potpuno isključivanje konzole

Odaberite **Power (Napajanje)**  u centru kontrola, a zatim odaberite **Turn Off PS5 (Isključi PS5)**. Indikator napajanja treperi belo i konzola će se zatim isključiti.

Indikator napajanja

Beli	Konzola je uključena.
Narandžasti	Konzola je u režimu odmaranja.
Isključen	Konzola je isključena.

Dodatne informacije

Vodič za bezbednost

Naučite kako da bezbedno koristite PS5 konzolu uz pomoć isporučenog Vodiča za bezbednost. Ovo odštampano uputstvo takođe sadrži uslove garancije za proizvod i informacije o specifikacijama. Obavezno ga pročitajte pre korišćenja konzole.

User's Guide (Korisnički vodič)

Saznajte sve o tome što PS5 konzola može da uradi. Naučite kako da konfigurirate postavke i kako da koristite svaku funkciju. Na početnom ekranu PS5 konzole, idite na Settings (Postavke)  > User's Guide, Health and Safety, and Other Information (Korisnički vodič, zdravlje i bezbednost i druge informacije) > User's Guide (Korisnički vodič).

Web lokacija za korisničku podršku

Pronađite informacije o podršci na mreži poput rešavanja problema korak po korak i najčešće postavljanih pitanja tako što ćete posetiti playstation.com/help/.



"PS", "PlayStation", "PS5", "PS4", "DualSense" i "PlayStation Shapes Logo" su registrovani zaštićeni žigovi ili zaštićeni žigovi kompanije Sony Interactive Entertainment Inc. "SONY" i "PS" su registrovani zaštićeni žigovi ili zaštićeni žigovi kompanije Sony Group Corporation.

The terms HDMI, HDMI High-Definition Multimedia Interface, HDMI Trade dress and the HDMI Logos are trademarks or registered trademarks of HDMI Licensing Administrator, Inc.

USB-IF SuperSpeed USB Trident logo is a registered trademark of USB Implementers Forum, Inc.

USB Type-C® and USB-C® are registered trademarks of USB Implementers Forum.

Wi-Fi® is a registered trademark of Wi-Fi Alliance®.

Dizajn i specifikacije podležu promeni bez najave.

Informacije o sistemskim funkcijama i slike objavljene u ovom dokumentu mogu se razlikovati od onih za vašu konzolu u zavisnosti od trenutne verzije sistemskog softvera. Osim toga, ilustracije i slike ekrana iz ovog priručnika mogu se razlikovati od stvarnog proizvoda.

Informacije sadržane u ovom vodiču podložne su izmenama bez prethodne najave.

Ας ξεκινήσουμε

1 Τοποθετήστε τα οριζόντια πόδια βάσης στην οπή που βρίσκεται στις αυλακώσεις της κονσόλας PlayStation®5.

Να τοποθετείτε πάντα τα πόδια στην κονσόλα PS5® πριν από τη χρήση. Πριν συνδέσετε τα πόδια, τοποθετήστε την κονσόλα πάνω σε ένα μαλακό πανί που έχετε απλώσει πάνω σε μια επίπεδη επιφάνεια.

Κονσόλα με εγκατεστημένη μονάδα δίσκου

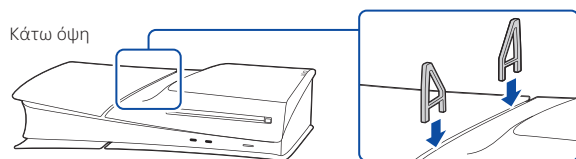

Κονσόλα χωρίς εγκατεστημένη μονάδα δίσκου

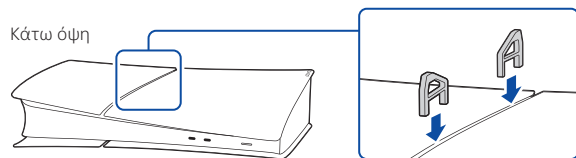

Αν θέλετε να ρυθμίσετε την κονσόλα PS5 σε κατακόρυφη θέση, θα πρέπει να χρησιμοποιήσετε την κάθετη βάση (πωλείται ξεχωριστά).

2 Συνδέστε το καλώδιο HDMI και το καλώδιο εναλλασσόμενου ρεύματος.

Χρησιμοποιήστε τα καλώδια που περιλαμβάνονται στη συσκευασία.

Κάντε όλες τις συνδέσεις πριν συνδέσετε το καλώδιο εναλλασσόμενου ρεύματος στην παροχή ρεύματος.

Όλες οι παρακάτω εικόνες απεικονίζουν την κονσόλα με εγκατεστημένη τη μονάδα δίσκου.

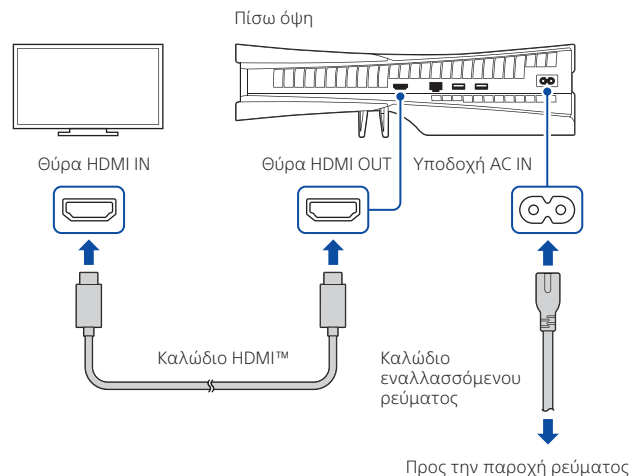

3 Συνδέστε το καλώδιο LAN.

Για ενσύρματη σύνδεση στο Internet, χρησιμοποιήστε καλώδιο LAN (δεν περιλαμβάνεται). Αν πρόκειται να χρησιμοποιήσετε Wi-Fi®, μην συνδέσετε καλώδιο LAN και προχωρήστε στο επόμενο βήμα.

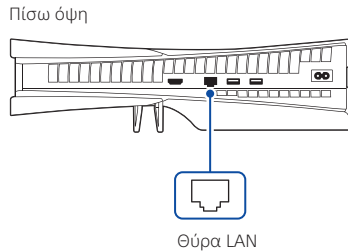

4 Ενεργοποιήστε την τηλεόρασή σας και επιλέξτε HDMI ως πηγή εισόδου.

5 Ενεργοποιήστε την κονσόλα PS5 πατώντας το κουμπί (λειτουργίας).

Η ένδειξη λειτουργίας αναβοσβήνει με μπλε χρώμα και έπειτα ανάβει με λευκό χρώμα.

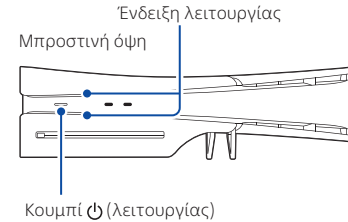

Αν αφήσετε την κονσόλα σε αδράνεια για 60 δευτερόλεπτα αφού την ενεργοποιήσετε, θα ενεργοποιηθεί ο αναγνώστης οθόνης. Με αυτήν τη λειτουργία, μπορείτε να ακούσετε μια φωνή να διαβάζει το κείμενο που εμφανίζεται στην οθόνη, για να κάνετε αυτό που θέλετε. Ο αναγνώστης οθόνης είναι διαθέσιμος μόνο σε συγκεκριμένες γλώσσες.

6 Συνδέστε το ασύρματο χειριστήριο DualSense® στην κονσόλα και πατήστε το κουμπί (PS).

Για να κάνετε σύζευξη του χειριστηρίου σας, συνδέστε το με ένα καλώδιο USB στη θύρα USB της κονσόλας. Όταν πατήσετε το κουμπί  (PS), το χειριστήριο θα ενεργοποιηθεί.

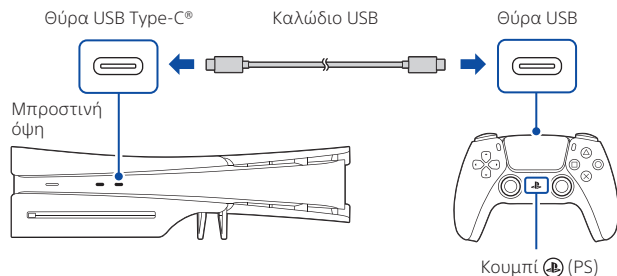

7 Προσαρμόστε το όπως θέλετε.

Σχεδόν τελειώσατε! Για να ολοκληρώσετε την αρχική ρύθμιση, ακολουθήστε τις οδηγίες στην οθόνη.

- Ρύθμιση του λογαριασμού σας
Δημιουργήστε ένα νέο λογαριασμό ή συνδεθείτε με έναν υπάρχοντα λογαριασμό. Αν συνδεθείτε με τον υπάρχοντα λογαριασμό σας, θα μπορείτε να έχετε πρόσβαση στη συνδρομή σας στο PlayStation®Plus, καθώς και σε φίλους, τρόπαια και άλλες πληροφορίες του λογαριασμού σας.
- Μεταφορά δεδομένων από άλλη κονσόλα
Αν έχετε κονσόλα PlayStation®4 ή μια άλλη κονσόλα PS5, μπορείτε να μεταφέρετε δεδομένα στη νέα σας κονσόλα, πραγματοποιώντας σύνδεση με έναν υπάρχοντα λογαριασμό.

Όταν ολοκληρωθεί η ρύθμιση, θα εμφανιστεί στην οθόνη σας το μήνυμα **Καλωσορίσατε στο PlayStation 5**.

Πρόκειται να χρησιμοποιήσει την κονσόλα PS5 κάποιο παιδί; Διαβάστε επίσης την ενότητα «Γονικός έλεγχος» (σελίδα 65).

- Οι επιλογές ρύθμισης που εμφανίζονται είναι προσαρμοσμένες στις δικές σας ανάγκες, ανάλογα με διάφορες πληροφορίες, όπως το περιβάλλον δικτύου σας και ο λογαριασμός στον οποίο έχετε συνδεθεί.
- Μπορείτε να επιστρέψετε και να αλλάξετε οποιαδήποτε ρύθμιση επιλέγοντας Ρυθμίσεις  από την αρχική οθόνη.

Γονικός έλεγχος

Μπορείτε να διαχειριστείτε τις ρυθμίσεις της κονσόλας PS5 σας, σε περίπτωση που υπάρχουν παιδιά που τη χρησιμοποιούν. Οι ρυθμίσεις γονικού ελέγχου σας επιτρέπουν να θέσετε περιορισμούς στα παιχνίδια που μπορούν να παίξουν τα παιδιά, στην ώρα και τη διάρκεια παιχνιδιού, στις δυνατότητες συνομιλίας και πολλά άλλα.

Κάθε ενήλικας (☺) και κάθε παιδί (☹) θα πρέπει να έχει τους δικούς τους, ξεχωριστούς λογαριασμούς. Όταν δημιουργείτε λογαριασμό για παιδί, αυτός ο λογαριασμός θα συνδέεται αυτομάτως με τον δικό σας λογαριασμό και θα γίνετε μέλη της ίδιας οικογένειας. Μπορείτε να επιλέξετε ρυθμίσεις γονικού ελέγχου μόνο για τα παιδιά που ανήκουν στην οικογένειά σας.

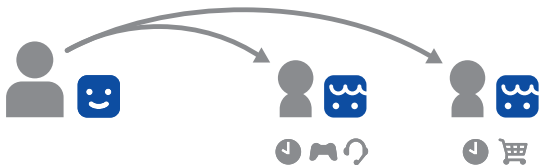

Μπορείτε να χρησιμοποιήσετε στην κονσόλα PS5 έναν υπάρχοντα λογαριασμό, όπως αυτόν που δημιουργήσατε σε μια κονσόλα PS4. Όλες οι ρυθμίσεις οικογενειακού και γονικού ελέγχου θα μεταφερθούν στην κονσόλα PS5.

Δημιουργία λογαριασμού για παιδί

Μπορείτε να δημιουργήσετε έναν λογαριασμό παιδιού, επιλέγοντας παράλληλα τις ρυθμίσεις γονικού ελέγχου. Πατήστε το κουμπί (PS) για να ανοίξετε το Κέντρο ελέγχου. Επιλέξτε την εικόνα προφίλ σας και στη συνέχεια **Αλλαγή χρήστη**. Για να δημιουργήσετε έναν λογαριασμό, επιλέξτε **Προσθήκη χρήστη** στην οθόνη επιλογής χρήστη.

Ελέγξτε και αλλάξτε τις ρυθμίσεις γονικού ελέγχου

Σας συνιστούμε να ελέγχετε τακτικά τις ρυθμίσεις γονικού ελέγχου του παιδιού σας. Για να τις ελέγξετε ή να τις ενημερώσετε, επιλέξτε **Ρυθμίσεις** ⚙ > **Οικογενειακοί και γονικοί έλεγχοι** στην οθόνη αρχικής σελίδας.

Εικονίδια καταλληλότητας παιχνιδιών

Κάθε παιχνίδι έχει ένα εικονίδιο καταλληλότητας παιχνιδιού που σας βοηθά να αποφασίσετε αν είναι κατάλληλο για την ηλικία του παιδιού σας.

Ευρώπη, Αφρική και Ινδία

Ηλικία του παίκτη	3 και πάνω	7 και πάνω	12 και πάνω	16 και πάνω	18 και πάνω
Ηλικιακή διαβάθμιση παιχνιδιών					

Γερμανία

Ηλικία του παίκτη	0 και πάνω	6 και πάνω	12 και πάνω	16 και πάνω	18 και πάνω
Ηλικιακή διαβάθμιση παιχνιδιών					

Για περισσότερες πληροφορίες σχετικά με τις λειτουργίες γονικού ελέγχου και τη ρύθμισή της, ανατρέξτε στον Οδηγό χρήσης (σελίδα 72).

Τι εμφανίζεται στην οθόνη

Οθόνη αρχικής σελίδας

Από την οθόνη αρχικής σελίδας, μπορείτε να μεταβείτε σε δύο είδη περιεχομένου: παιχνίδια ή πολυμέσα.

Στην αρχική σελίδα παιχνιδιών, θα βρείτε τα παιχνίδια σας, το PlayStation™Store και άλλες εφαρμογές που σχετίζονται με παιχνίδια.

Στην αρχική σελίδα πολυμέσων, θα βρείτε μουσική, βίντεο και άλλες εφαρμογές που δεν σχετίζονται με παιχνίδια.

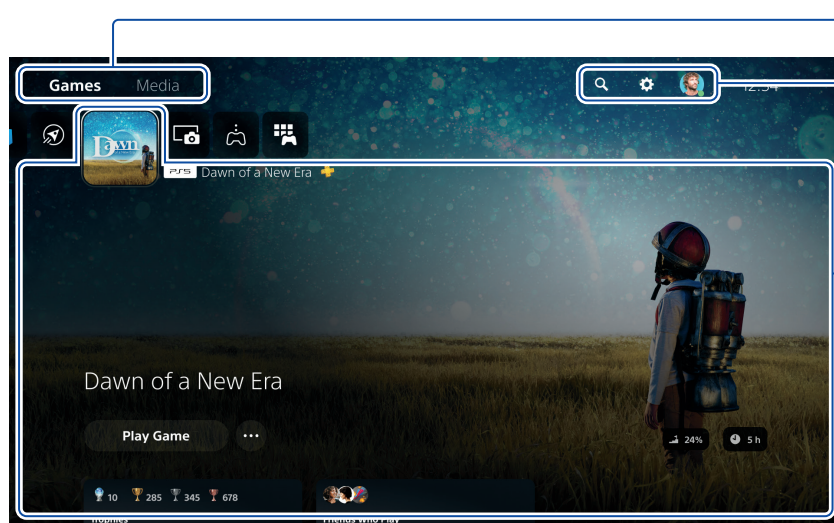

Εναλλαγή οθονών αρχικών σελίδων

Εναλλαγή παιχνιδιών και πολυμέσων.

Αλλάξτε τις ρυθμίσεις σας, αναζητήστε και επεξεργαστείτε το προφίλ σας.

Hub

Μάθετε περισσότερα σχετικά με το παιχνίδι ή την εφαρμογή που έχετε επιλέξει και βρείτε σχετικές πληροφορίες.

- Στην κονσόλα PS5, το κουμπί (X) επιβεβαιώνει τις επιλογές σας.
- Για να επιστρέψετε στην οθόνη αρχικής σελίδας ενώ εκτελείται το παιχνίδι ή η εφαρμογή σας, επιλέξτε **Αρχική σελίδα** (Home) από το κέντρο ελέγχου ή πατήστε παρατεταμένα το κουμπί (PS) στο χειριστήριό σας.

EL

Τι εμφανίζεται στην οθόνη

Κέντρο ελέγχου

Πατήστε το κουμπί (PS) για να ανοίξετε το κέντρο ελέγχου.

Μπορείτε να χρησιμοποιήσετε διάφορες λειτουργίες, χωρίς να κλείσετε το παιχνίδι ή την εφαρμογή σας.



Κάρτες

Οι κάρτες δείχνουν λειτουργίες και δραστηριότητες που σχετίζονται με τα παιχνίδια και τις εφαρμογές σας, οι οποίες είναι διαθέσιμες ανάλογα με αυτό που κάνετε τη συγκεκριμένη στιγμή. Επιλέξτε μια κάρτα για να μάθετε περισσότερα ή μεταβείτε στην επόμενη κάρτα.

Στοιχεία ελέγχου

Επιλέξτε **Αρχική σελίδα** για να επιστρέψετε στην οθόνη αρχικής σελίδας και επιλέξτε **Λειτουργία** για να απενεργοποιήσετε την κονσόλα PS5. Εδώ μπορείτε να εκτελέσετε κι άλλες βασικές λειτουργίες.

Αποκτήστε γρήγορη πρόσβαση στις λειτουργίες και τις ρυθμίσεις που χρησιμοποιείτε συχνά όταν παίζετε παιχνίδια.

Ας παίξουμε

Παίξτε ένα ψηφιακό παιχνίδι

Μπορείτε να παίξετε ένα παιχνίδι που έχετε κατεβάσει από το **PlayStation Store** .

Θα λάβετε μια ειδοποίηση όταν ολοκληρωθεί η λήψη του παιχνιδιού και θα είναι έτοιμο για να παίξετε.

Επιλέξτε παιχνίδι από την αρχική σελίδα παιχνιδιών.

- Για να αγοράσετε και να κατεβάσετε παιχνίδια, πρέπει να συνδέσετε την κονσόλα σας στο Internet και να συνδεθείτε στον λογαριασμό σας.
- Το PlayStation™Network και το PlayStation Store υπόκεινται σε όρους χρήσης, καθώς και σε περιορισμούς βάσει χώρας και γλώσσας. Οι χρήστες επιβαρύνονται με τις χρεώσεις χρήσης του Internet. Ισχύουν χρεώσεις για συγκεκριμένο περιεχόμενο ή/και υπηρεσίες. Οι χρήστες πρέπει να έχουν συμπληρώσει το 7ο έτος της ηλικίας τους. Για τους χρήστες κάτω των 18 ετών απαιτείται η γονική συναίνεση. Ενδέχεται να ισχύουν επιπλέον ηλικιακοί περιορισμοί. Η διαθεσιμότητα των υπηρεσιών δεν είναι εγγυημένη. Ορισμένες διαδικτυακές λειτουργίες συγκεκριμένων παιχνιδιών ενδέχεται να διακοπούν κατόπιν εύλογης προειδοποίησης - βλ. playstation.com/gameservers. Ισχύουν πλήρεις όροι: Όροι υπηρεσίας του PSN στη διεύθυνση playstation.com/legal/.

Παίξτε ένα παιχνίδι από δίσκο

(Μόνο για κονσόλες με εγκατεστημένη μονάδα δίσκου)

Εισαγάγετε τον δίσκο.

Θα ξεκινήσει η εγκατάσταση των δεδομένων του παιχνιδιού και θα λάβετε μια ειδοποίηση όταν το παιχνίδι είναι έτοιμο.

Επιλέξτε το παιχνίδι από την αρχική σελίδα των παιχνιδιών σας.

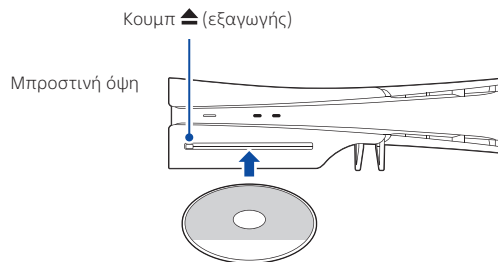

Αφαίρεση του δίσκου

Πατήστε το κουμπί  (εξαγωγής) για να βγάλετε τον δίσκο.

Χρήση του χειριστηρίου

Φόρτιση του χειριστηρίου

Όταν η κονσόλα PS5 είναι ενεργοποιημένη ή σε λειτουργία αδράνειας, συνδέστε το χειριστήριό σας στην κονσόλα με ένα καλώδιο USB. Όταν η κονσόλα είναι σε λειτουργία αδράνειας, η φωτιζόμενη μπάρα στο χειριστήριο αναβοσβήνει αργά με πορτοκαλί χρώμα. Όταν η φόρτιση ολοκληρωθεί, η φωτιζόμενη μπάρα σβήνει.

Για να φορτίσετε το χειριστήριο όταν η κονσόλα είναι σε λειτουργία αδράνειας, μεταβείτε στην επιλογή Ρυθμίσεις ⚙ > Σύστημα > Εξοικονόμηση ενέργειας > Δυνατότητες που διατίθενται στη λειτουργία αδράνειας > Παροχή τροφοδοσίας στις θύρες USB, και επιλέξτε οτιδήποτε άλλο εκτός από Απενεργοποιημένο.

Σίγαση μικροφώνου

Κάθε φορά που πατάτε το κουμπί σίγασης, το μικρόφωνό σας κάνει εναλλαγή μεταξύ σίγασης (κουμπί αναμμένο) και αναίρεσης σίγασης (κουμπί σβηστό).

Πατήστε παρατεταμένα το κουμπί σίγασης για να γίνει σίγαση στο μικρόφωνό σας και απενεργοποιήστε την έξοδο ήχου από τα ηχεία στο χειριστήριο και την τηλεόρασή σας. Πατήστε το κουμπί σίγασης ξανά για να επιστρέψετε στην αρχική κατάσταση.

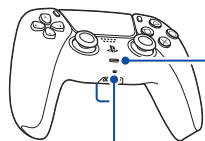

Μικρόφωνα

 Κουμπί σίγασης
Αναμμένο : Το μικρόφωνο είναι σε σίγαση
Σβηστό : Έχει αναρθεθεί η σίγαση στο μικρόφωνο
Αναβοσβήνει: Το μικρόφωνο και η έξοδος ήχου είναι σε σίγαση

Χρήση πολλών χειριστηρίων

Μπορείτε να χρησιμοποιήσετε έως και 4 χειριστήρια ταυτόχρονα. Πατήστε το κουμπί (PS) για να αντιστοιχίσετε αριθμούς στα χειριστήριά σας. Οι λυχνίες των ενδείξεων παικτών ανάβουν αντίστοιχα. Οι αριθμοί αντιστοιχίζονται διαδοχικά από το 1 και ο αριθμός κάθε χειριστηρίου υποδεικνύεται από τον αριθμό των φωτεινών ενδείξεων που ανάβουν.

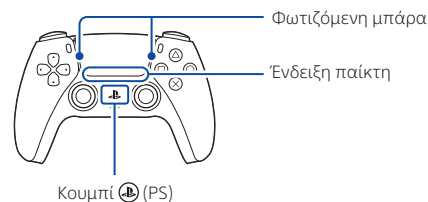

- Θα πρέπει να κάνετε σύζευξη του χειριστηρίου όταν το χρησιμοποιήσετε για πρώτη φορά (σελίδα 64).
- Όταν παίζετε παιχνίδια του PS4, η φωτιζόμενη μπάρα του χειριστηρίου σας ανάβει μπλε, κόκκινη, πράσινη ή ροζ, ανάλογα με τη σειρά που συνδέθηκε κάθε χειριστήριο. Αυτό δεν σχετίζεται με την ένδειξη παίκτη.

Ενεργοποιήστε την κονσόλα PS5 από το χειριστήριο

Πατήστε το κουμπί (PS) σε ένα χειριστήριο που έχει συζευχθεί με την κονσόλα για να ενεργοποιήσετε την κονσόλα PS5.

Απενεργοποίηση



Προσοχή

Αποσυνδέστε το καλώδιο εναλλασσόμενου ρεύματος από την παροχή ρεύματος, μόνο όταν η ένδειξη λειτουργίας είναι απενεργοποιημένη. Αν αποσυνδέσετε το καλώδιο ενώ η ένδειξη λειτουργίας είναι αναμμένη ή αναβοσβήνει, υπάρχει κίνδυνος απώλειας ή καταστροφής δεδομένων, ενώ μπορεί να προκληθεί βλάβη και στην κονσόλα.

Θέστε την κονσόλα σε λειτουργία αδράνειας

Η λειτουργία εξοικονόμησης ενέργειας της κονσόλας PS5 λέγεται λειτουργία αδράνειας. Ενώ η κονσόλα βρίσκεται σε αυτήν την κατάσταση χαμηλής κατανάλωσης ενέργειας, μπορείτε να κάνετε διάφορα πράγματα, όπως να φορτίζετε το χειριστήριό σας από τις θύρες USB της κονσόλας, να ενημερώνετε αυτόματα το λογισμικό συστήματος και να διατηρείτε το παιχνίδι ή την εφαρμογή σας σε κατάσταση ετοιμότητας. Για να βρείτε τις κατάλληλες ρυθμίσεις λειτουργίας αδράνειας για εσάς, ανατρέξτε στον Οδηγό χρήσης (σελίδα 72).

Για ορισμένες λειτουργίες, θα πρέπει να ενεργοποιήσετε τις αντίστοιχες ρυθμίσεις για να εμφανιστούν. Μεταβείτε στην επιλογή Ρυθμίσεις  > Σύστημα > Εξοικονόμηση ενέργειας > Δυνατότητες που διατίθενται στη λειτουργία αδράνειας.

Επιλέξτε **Λειτουργία**  από το κέντρο ελέγχου και μετά επιλέξτε **Είσοδος σε λειτουργία αδράνειας**. Η ένδειξη λειτουργίας αναβοσβήνει με λευκό χρώμα και έπειτα γίνεται πορτοκαλί. Για έξοδο από τη λειτουργία αδράνειας, πατήστε το κουμπί  (PS).

Πλήρης απενεργοποίηση της κονσόλας

Επιλέξτε **Λειτουργία**  από το κέντρο ελέγχου και μετά επιλέξτε **Απενεργοποίηση του PS5**. Η ένδειξη λειτουργίας αναβοσβήνει με λευκό χρώμα και η κονσόλα απενεργοποιείται.

Ένδειξη λειτουργίας

Λευκό	Η κονσόλα είναι ενεργοποιημένη.
Πορτοκαλί	Η κονσόλα βρίσκεται σε λειτουργία αδράνειας.
Απενεργοποιημένη	Η κονσόλα είναι απενεργοποιημένη.

Περισσότερες πληροφορίες

Οδηγός ασφάλειας

Μάθετε πώς να χρησιμοποιείτε την κονσόλα PS5 με ασφάλεια με τον Οδηγό ασφάλειας που περιλαμβάνεται στη συσκευασία. Αυτό το έντυπο εγχειρίδιο περιέχει επίσης τους όρους της εγγύησης και πληροφορίες σχετικά με τις προδιαγραφές του προϊόντος. Φροντίστε να το διαβάσετε προτού χρησιμοποιήσετε την κονσόλα.

Οδηγός χρήσης

Ανακαλύψτε όλα όσα μπορεί να κάνει η κονσόλα PS5. Μάθετε πώς μπορείτε να διαμορφώσετε τις ρυθμίσεις και να χρησιμοποιήσετε κάθε λειτουργία.

Από την οθόνη αρχικής σελίδας της κονσόλας PS5, μεταβείτε στην επιλογή **Ρυθμίσεις** > **Οδηγός χρήσης, υγεία και ασφάλεια και άλλες πληροφορίες** > **Οδηγός χρήσης**.

Διαδικτυακή τοποθεσία Υποστήριξης πελατών

Επισκεφτείτε την τοποθεσία playstation.com/help/ για να βρείτε διαδικτυακή υποστήριξη, όπως αντιμετώπιση προβλημάτων βήμα προς βήμα και απαντήσεις σε συνήθεις ερωτήσεις.



Τα "PS", "PlayStation", "PS5", "PS4", "DualSense" και "PlayStation Shapes Logo" είναι κατοχυρωμένα εμπορικά σήματα ή σήματα κατατεθέντα της Sony Interactive Entertainment Inc.

Τα "SONY" και "PS" είναι κατοχυρωμένα εμπορικά σήματα της Sony Group Corporation.

The terms HDMI, HDMI High-Definition Multimedia Interface, HDMI Trade dress and the HDMI Logos are trademarks or registered trademarks of HDMI Licensing Administrator, Inc.

USB-IF SuperSpeed USB Trident logo is a registered trademark of USB Implementers Forum, Inc.

USB Type-C® and USB-C® are registered trademarks of USB Implementers Forum.

Wi-Fi® is a registered trademark of Wi-Fi Alliance®.

Ο σχεδιασμός και οι προδιαγραφές μπορούν να τροποποιηθούν χωρίς προειδοποίηση.

Οι πληροφορίες σχετικά με τη λειτουργικότητα του συστήματος και οι εικόνες που δημοσιεύονται στο παρόν έγγραφο ενδέχεται να διαφέρουν από τα αντίστοιχα της δικής σας κονσόλας, ανάλογα με την έκδοση λογισμικού που χρησιμοποιείτε. Επίσης, τα σχέδια και οι εικόνες οθονών που χρησιμοποιούνται στον παρόντα οδηγό ενδέχεται να διαφέρουν από το πραγματικό προϊόν.

Οι πληροφορίες που περιέχονται σε αυτόν τον οδηγό υπόκεινται σε αλλαγές χωρίς ειδοποίηση.

Başlangıç

1 Yatay stant ayaklarını PlayStation®5 konsolunun oluklarındaki deliğe yerleştirin.

Kullanmadan önce her zaman ayakları PS5® konsolunuza takın. Ayakları takmadan önce konsolunuzu düz bir yüzeye serilmiş yumuşak bir bez üzerine yerleştirin.

Disk sürücü takılı konsol

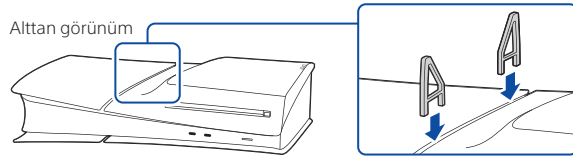

Disk sürücü takılı olmayan konsol

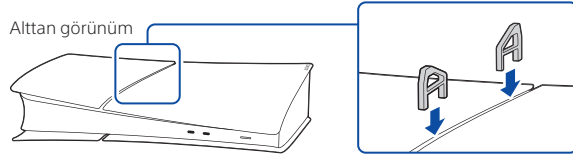

PS5 konsolunuzu dikey konuma ayarlamak istiyorsanız dikey standı kullanmanız gerekir (ayrı satılır).

2 HDMI kablosunu ve AC güç kablosunu bağlayın.

Kutuya dahil olan kabloları kullanın. AC güç kablosunu prize takmadan önce tüm bağlantıları yapın.

Aşağıdaki çizimlerin tümü, disk sürücü takılı konsolu göstermektedir.

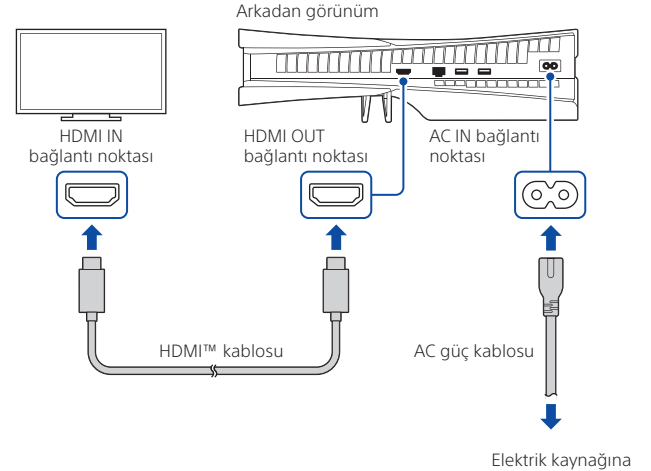

3 LAN kablosunu bağlayın.

Kablolu internet bağlantısı için LAN kablosu kullanın (dahil değildir).
Wi-Fi® kullanacaksanız bir LAN kablosu bağlamayın ve bir sonraki adıma geçin.

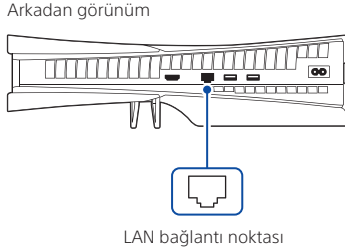

4 TV'nizi açın ve girişi HDMI seçeneğine ayarlayın.

5 (güç) düğmesine basarak PS5 konsolunuzu açın.

Güç göstergesi mavi renkte yanıp söner, ardından beyaz renkte yanar.

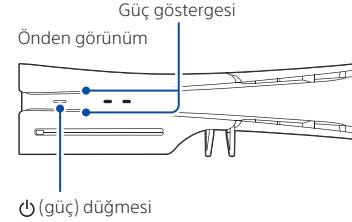

Konsolu açtıktan sonra 60 saniye boyunca herhangi bir eylemde bulunmazsanız ekran okuyucu açılır. İstediklerinizi gerçekleştirmek için ekrandaki metinlerin ve diğer önemli bilgilerin sesli okunmasını dinleyebilirsiniz. Ekran okuyucu yalnızca belirli dillerde mevcuttur.

6 DualSense® kablosuz kontrol cihazınızı konsolunuza bağlayın ve (PS) düğmesine basın.

Kontrol cihazınızı, USB kablosuyla konsolunuzun USB bağlantı noktasına bağlayarak eşleştirin.

(PS) düğmesine bastığınızda kontrol cihazı açılır.

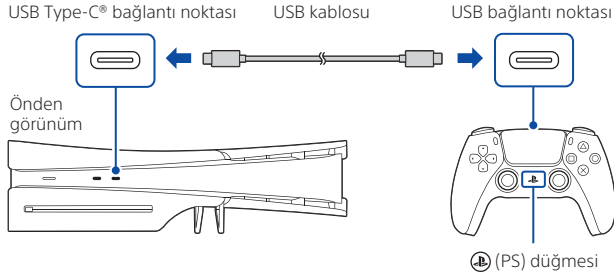

7 Dilediğiniz gibi kişiselleştirin.

Neredeyse bitti! Başlangıç ayarlarını tamamlamak için ekrandaki talimatları izleyin.

- Hesabınızı ayarlayın
Yeni bir hesap oluşturun veya mevcut bir hesapla giriş yapın. Mevcut hesabınızla giriş yaparak PlayStation®Plus aboneliğinize, arkadaşlarınıza, kupalara ve diğer hesap bilgilerine erişebilirsiniz.
- Başka bir konsoldan verileri aktarma
PlayStation®4 konsolunuz veya başka bir PS5 konsolunuz varsa mevcut bir hesapla oturum açarak yeni konsolunuza verileri aktarabilirsiniz.

Ekranınızda **PlayStation 5'e hoş geldiniz** yazısını gördüğünüzde kurulumun tamamlandığını anlayabilirsiniz.

PS5 konsolunuz çocuklar tarafından kullanılacak mı? Ayrıca bkz. "Ebeveyn kontrolleri" (sayfa 77).

- Gördüğünüz kurulum seçenekleri; ağ ortamınız ve oturum açtığınız hesap gibi bilgiler temel alınarak ihtiyaçlarınıza göre özel olarak oluşturulmuştur.
- Ana ekrandan **Ayarlar** ⚙️ ögesini seçerek geri dönüp ayarlarınızı değiştirebilirsiniz.

Ebeveyn kontrolleri

PS5 konsolunuzu kullanan çocuklarınız için ayarları yönetebilirsiniz. Ebeveyn kontrolleri, çocukların oynayabileceği oyunlar, ne zaman ve ne kadar süre boyunca oynayabilecekleri, sohbet edip edemeyecekleri ve daha fazlası ile ilgili sınırlandırmalar belirlemenizi sağlar.

Her bir yetişkinin (👤) ve çocuğun (👶) ayrı hesaplara sahip olması gerekir. Bir çocuk hesabı oluşturduğunuzda bu hesap otomatik olarak hesabınıza bağlanarak bir aile oluşturulur. Yalnızca kendi ailenizdeki çocuklara ebeveyn kontrolleri ayarlayabilirsiniz.

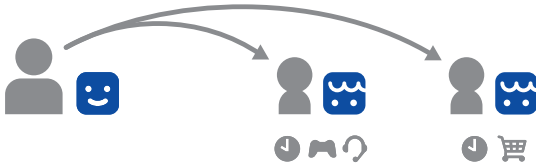

PS4 konsolunda oluşturduğunuz bir hesap gibi mevcut bir hesabı, PS5 konsolunuzda kullanabilirsiniz. Aile ve ebeveyn kontrolü ayarlarınız, PS5 konsolunuza taşınacaktır.

Bir çocuk için hesap oluşturun

Çocuk hesabı oluşturduğunuz anda ebeveyn kontrolleri de ayarlayabilirsiniz. Kontrol merkezini açmak için (PS) düğmesine basın. Profil resminizi seçin, ardından **Kullanıcı Değiştir**'i seçin. Bir hesap oluşturmak için kullanıcı seçimi ekranından **Kullanıcı Ekle**'yi seçin.

Ebeveyn kontrolü ayarlarınızı gözden geçirip değiştirin

Çocuğunuzun ebeveyn kontrolü ayarlarını düzenli olarak kontrol etmenizi öneririz. Giriş ekranından **Ayarlar** ⚙️ > **Aile ve Ebeveyn** öğesini seçerek bunları gözden geçirebilir ya da güncelleyebilirsiniz.

Ebeveyn kontrolleri

Oyun derecelendirme simgeleri

Her oyunda, çocuğunuzun yaşı için uygun olup olmadığını belirlemenize yardımcı olan bir oyun derecelendirme simgesi bulunur.

Avrupa, Afrika ve Hindistan

Oyuncunun Yaşı	3 yaş ve üzeri	7 yaş ve üzeri	12 yaş ve üzeri	16 yaş ve üzeri	18 yaş ve üzeri
Oyun Yaş Derecelendirmesi					

Almanya

Oyuncunun Yaşı	0 yaş ve üzeri	6 yaş ve üzeri	12 yaş ve üzeri	16 yaş ve üzeri	18 yaş ve üzeri
Oyun Yaş Derecelendirmesi					

Kullanım Kılavuzu'ndan (sayfa 84) ebeveyn kontrolü özellikleri ve kurulumuna dair daha fazla bilgi alabilirsiniz.

Ekranla olanlar

Giriş ekranı

Giriş ekranından, oyunlar veya medya olmak üzere iki içerik türüne gidebilirsiniz.

Oyun ana ekranında oyunlarınızı, PlayStation™Store'u ve oyunlarla ilgili diğer uygulamaları bulabilirsiniz.

Medya ana ekranında müzik, video ve oyunlarla ilgili olmayan diğer uygulamaları bulabilirsiniz.

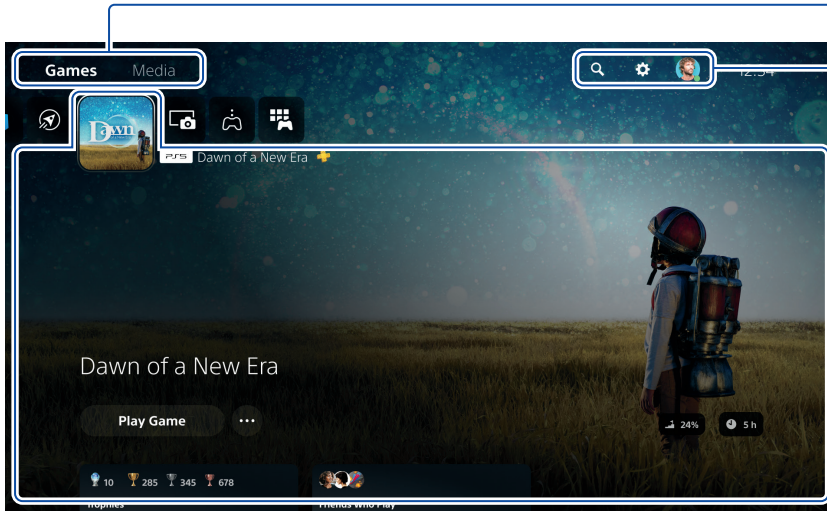

Giriş ekranları arasında geçiş yapın

Oyunlar ve medya arasında geçiş yapın.

Arayın, ayarlarınızı değiştirin ve profilinizi düzenleyin.

Merkez

Seçtiğiniz oyun veya uygulama hakkında daha fazla şey öğrenip ilgili bilgilere ulaşabilirsiniz.

- PS5 konsolunuzda (X) düğmesi, seçili öğeleri onaylar.
- Oyununuz veya uygulamanız çalışırken giriş ekranına dönmek için kontrol merkezinden Ana Ekran (Home) ögesini seçebilir ya da kontrol cihazınızdaki (PS) düğmesini basılı tutabilirsiniz.

Kontrol merkezi

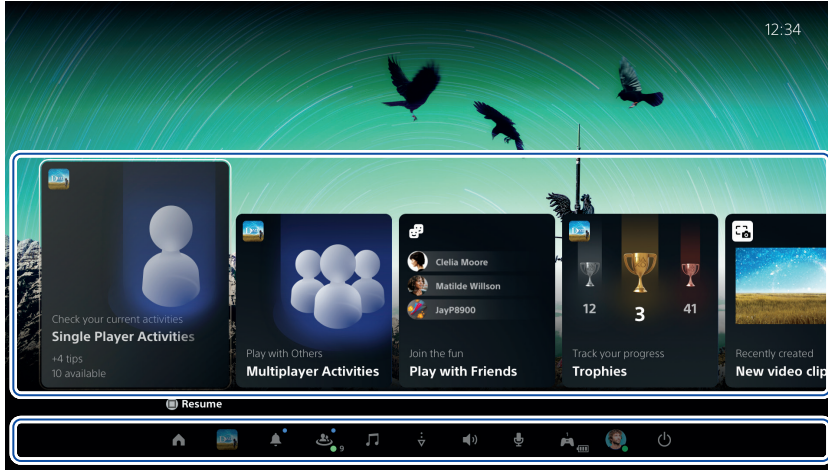

Kontrol merkezini açmak için (PS) düğmesine basın. Oyununuzdan veya uygulamanızdan çıkmadan çeşitli özelliklere erişebilirsiniz.



Kartlar

Kartlar, o andaki eyleminize göre oyunlarınız ve uygulamalarınızla ilgili özellikleri ya da etkinlikleri gösterir. Daha fazla bilgi edinmek için bir kart seçin ya da bir sonraki karta geçin.

Kontroller

Giriş ekranınıza dönmek için **Ana Ekran**  öğesini seçin ve PS5 konsolunuzu kapatmak için **Güç**  öğesini seçin. Buradan diğer temel işlevleri de yerine getirebilirsiniz.

Oyun sırasında en çok kullandığınız işlevlere ve ayarlara hızlıca erişin.

Haydi oynayalım

Bir dijital oyun oynama

PlayStation Store  üzerinden oyun indirip oynayabilirsiniz. Oyununuz indirilip oynanmaya hazır olduğunda bir bildirim alacaksınız. Oyun ana ekranınızdan oyunu seçin.

- Oyun satın alıp indirmek için konsolunuzu internete bağlamanız ve hesabınızda oturum açmanız gerekir.
- PlayStation™Network ve PlayStation Store; kullanım şartları ve yaş ile dil kısıtlamalarına tabidir. İnternet hizmeti ücretlidir. Kullanıcılar en az 7 yaşında olmalıdır ve 18 yaşından küçük kullanıcılar ebeveynlerinden onay almalıdır. Ek yaş sınırlamaları geçerli olabilir. Hizmetin kullanılabilirliği garanti edilmez. Bazı oyunların çevrimiçi özellikleri önceden haber verilerek kaldırılabilir: playstation.com/gameservers. Tüm koşullar geçerlidir: PSN Hizmet Koşullarını playstation.com/legal/ adresinde bulabilirsiniz.

Diskten oyun oynama

(Yalnızca disk sürücüsü takılı konsollar için)

Diski takın.
Oyun verileri yüklenmeye başlar ve oyun oynanmaya hazır olduğunda bir bildirim alırsınız.
Oyun ana ekranınızdan oyunu seçin.

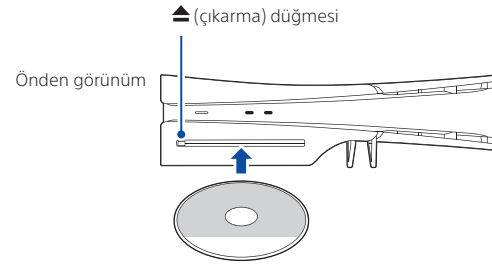

Diski çıkarma

Diski çıkarmak için  (çıkarma) düğmesine basın.

Kontrol cihazınızı kullanma

Kontrol cihazınızı şarj etme

PS5 konsolunuz açıkken veya dinlenme modundayken USB kablosuyla kontrol cihazınızı konsola bağlayın. Konsolunuz dinlenme modundayken kontrol cihazınızın üzerindeki ışıklı çubuk yavaş yavaş turuncu renkte yanıp söner. Şarj etme işlemi tamamlandıktan sonra ışıklı çubuk söner.

Konsolunuz dinlenme modundayken **Ayarlar** ⚙️ > **Sistem** > **Güç Tasarrufu** > **Dinlenme Modunda Kullanılabilen Özellikler** > **USB Bağlantı Noktalarına Güç Sağla**, bölümüne gidin ve **Kapalı** dışında bir seçenek belirleyin.

Mikrofonunuzu sessize alın

Sessize alma düğmesine her bastığınızda mikrofonunuz kapalı (düğme yanar) ve açık (düğme sönük) arasında değişir.

Mikrofonunuzu sessize almak ve kontrol cihazı ile TV'nizdeki hoparlörlerden gelen ses çıkışı kapatmak için sessize alma düğmesini basılı tutun. İlk durumuna döndürmek için sessize alma düğmesine tekrar basın.

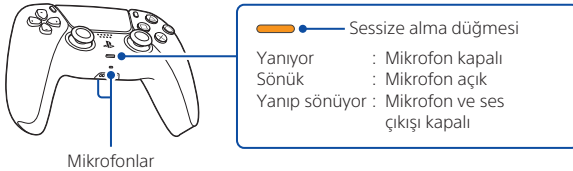

Birden fazla kontrol cihazı kullanma

Bir seferde en fazla 4 kontrol cihazı kullanabilirsiniz. Kontrol cihazınıza numara atamak için (PS) düğmesine basın. Oyuncu göstergesi ışıkları buna göre yanar. Numaralar 1'den itibaren sırayla atanır; böylece yanar ışık miktarına göre kontrol cihazınızın numarasını tespit edebilirsiniz.

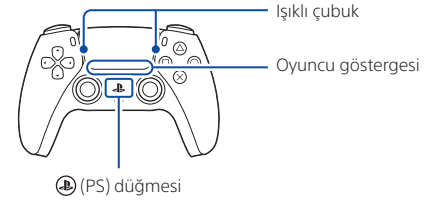

- İlk kez kullanmadan önce kontrol cihazınızı eşleştirmeniz gerekir (sayfa 76).
- Bir PS4 oyunu oynarken, kontrol cihazınızın ışıklı çubuğu, bağlı olan kontrol cihazı sırasına göre mavi, kırmızı, yeşil veya pembe renkte yanar. Bu, oyuncu göstergesinden ayrıdır.

Kontrol cihazıyla PS5 konsolunuzu açma

PS5 konsolunuzu açmak için eşleştirme işlemi tamamlanmış bir kontrol cihazından (PS) düğmesine basın.

Kapatma

⚠ Dikkat

AC güç kablosunu yalnızca güç göstergesi kapalı olduğunda elektrik kaynağından çıkarın. Güç kablosunu güç göstergesi sabit yanarken veya yanıp sönerken çıkarırsanız veri kaybı veya bozulması gerçekleşebilir ve konsolunuza zarar verebilirsiniz.

Konsolunuzu dinlenme moduna alma

PS5 konsolunuzun güç tasarrufu moduna dinlenme modu adı verilir. Konsolunuzun USB bağlantı noktaları üzerinden kontrol cihazınızı şarj etme, sistem yazılımınızı otomatik olarak güncelleme ve konsolunuza güç verilmeyen oyunlarınızı veya uygulamalarınızı askıya almak gibi işlemler gerçekleştirebilirsiniz. Hangi dinlenme modu ayarlarının size uygun olduğunu öğrenmek için Kullanım Kılavuzuna başvurun (sayfa 84).

Bazı özellikleri kullanabilmek için ayarlarını etkinleştirmeniz gerekir. **Ayarlar** ⚙ > **Sistem** > **Güç Tasarrufu** > **Dinlenme Modunda Kullanılabilen Özellikler** bölümüne gidin.

Kontrol merkezinden **Güç** ⏻ ögesini seçin ve ardından **Dinlenme Moduna Git** ögesini seçin. Güç göstergesi beyaz renkte yanıp söner, ardından turuncuya döner. Dinlenme modundan çıkmak için **(PS)** düğmesine basın.

Konsolunuzu tamamen kapatma

Kontrol merkezinden **Güç** ⏻ ögesini seçin ve ardından **PS5 Sistemini Kapat** ögesini seçin. Güç göstergesi beyaz renkte yanıp söner, ardından konsol kapanır.

Güç göstergesi

Beyaz	Konsol açık.
Turuncu	Konsol dinlenme modunda.
Kapalı	Konsol kapalı.

Daha fazla bilgi

Güvenlik Kılavuzu

Birlikte verilen Güvenlik Kılavuzunu kullanarak PS5 konsolunuzu güvenli bir şekilde nasıl kullanacağınızı öğrenin. Bu basılı kılavuz aynı zamanda ürün garantisi şartları ve teknik özelliklere dair bilgiler de içerir. Konsolunuzu kullanmadan önce bu kılavuzu mutlaka okuyun.

Kullanım Kılavuzu

PS5 konsolunuzun tüm yapabildiklerini öğrenin. Ayarları nasıl yapılandıracağınızı ve her işlevi nasıl kullanacağınızı öğrenin. PS5 konsolunuzun giriş ekranından **Ayarlar**  > **Kullanım Kılavuzu**, **Sağlık ve Güvenlik ve Diğer Bilgiler** > **Kullanım Kılavuzu** bölümüne gidin.

Müşteri Desteği Web Sitesi

Şu adresi ziyaret ederek adım adım sorun giderme ve sık sorulan sorular gibi çevrimiçi destek bilgileri bulabilirsiniz: playstation.com/help/.



"PS", "PlayStation", "PSS", "PS5", "PS4", "DualSense" ve "PlayStation Shapes Logo" Sony Interactive Entertainment Inc. in tescilli ticari markaları veya ticari markalarıdır. "SONY" ve "PS" Sony Group Corporation'ın tescilli ticari markaları veya ticari markalarıdır. The terms HDMI, HDMI High-Definition Multimedia Interface, HDMI Trade dress and the HDMI Logos are trademarks or registered trademarks of HDMI Licensing Administrator, Inc. USB-IF SuperSpeed USB Trident logo is a registered trademark of USB Implementers Forum, Inc. USB Type-C® and USB-C® are registered trademarks of USB Implementers Forum. Wi-Fi® is a registered trademark of Wi-Fi Alliance®. Tasarımda ve teknik özelliklerde haber verilmeden değişiklik yapılabilir. Bu belgede yayınlanan sistem işlevselliğiyle ilgili bilgiler ve resimler, kullanılan sistem yazılımı sürümüne bağlı olarak konsolunuzdakilerden farklı olabilir. Ayrıca, bu kılavuzda kullanılan çözümler ve ekran resimleri asıl üründen farklı olabilir. Bu kılavuzda bulunan bilgiler haber verilmeksizin değiştirilebilir.



© 2023 Sony Interactive Entertainment Europe Limited.





© 2023 Sony Interactive Entertainment Europe Limited.

מידע נוסף

מדריך בטיחות

למד כיצד להשתמש בבטחה בקונסולת ה-PS5 באמצעות מדריך הבטיחות המצורף. מדריך מודפס זה מכיל גם את תנאי אחריות המוצר ומידע לגבי המפרט. הקפד לקרוא אותו לפני השימוש בקונסולה.

User's Guide (מדריך למשתמש)

גלה את כל הדברים שקונסולת PS5 יכולה לעשות. למד כיצד לקבוע תצורה של הגדרות ולהשתמש בכל פונקציה.

ממסך הבית של קונסולת PS5, עבור אל **Settings (הגדרות)** < **User's Guide, Health and Safety, and Other Information (מדריך למשתמש, בריאות ובטיחות ומידע אחר)** < **User's Guide (מדריך למשתמש)**.

אתר תמיכה בלקוחות

כדי לחפש מידע בתמיכה המקוונת, כגון פתרון בעיות מפורט ושאלות נפוצות, בקר באתר playstation.com/help/.



"PS5", "PlayStation", "PS4", "DualSense", "PS5", "PS4", "PS5" ו-"PlayStation Shapes Logo" הם סימנים מסחריים רשומים או סימנים מסחריים של Sony Interactive Entertainment Inc. "SONY" ו-"PS5" הם סימנים מסחריים רשומים או סימנים מסחריים של Sony Group Corporation.

The terms HDMI, HDMI High-Definition Multimedia Interface, HDMI Trade dress and the HDMI Logos are trademarks or registered trademarks of HDMI Licensing Administrator, Inc.

USB-IF SuperSpeed USB Trident logo is a registered trademark of USB Implementers Forum, Inc.

USB Type-C® and USB-C® are registered trademarks of USB Implementers Forum.

Wi-Fi® is a registered trademark of Wi-Fi Alliance®.

המבנה והמפרט עשויים להשתנות ללא הודעה מוקדמת. המידע על הפונקציונליות של המערכת והתמונות המפורסמות במסמך זה עשויים להיות שונים בקונסולה שלך, בהתאם לגרסת תוכנת המערכת שבשימוש. כמו כן, האיורים ותמונות המסך שנעשה בהם שימוש במדריך זה עשויים להיות שונים מהמוצר בפועל. המידע הכלול במדריך זה נתון לשינויים ללא הודעה מראש.

מחווון הפעלה

לבן	הקונסולה פועלת.
כתום	הקונסולה נמצאת במצב מנוחה.
כבוי	הקונסולה כבויה.

⚠️ זהירות

נתק את כבל מתח ה-AC משקע החשמל רק כאשר מחווון ההפעלה כבוי. אם נתק אותו כאשר מחווון ההפעלה מאיר קבוע או מהבהב, ייתכן שנתונים יאבדו או ייפגעו, ועלול להיגרם נזק לקונסולה.

העברת הקונסולה למצב מנוחה

מצב החיסכון בחשמל של קונסולת ה-PS5 נקרא מצב מנוחה. באפשרותך לבצע דברים, כמו לטעון את הבקר דרך יציאת ה-USB של הקונסולה, לעדכן אוטומטית את תוכנת המערכת ולהשהות את המשחק או האפליקציה בזמן הפסקת חשמל. כדי לגלות אילו הגדרות מצב מנוחה אופטימליות עבורך, עיין User's Guide (מדריך למשתמש) (עמוד 12).

לתכונות מסוימות, תצטרך לאפשר את ההגדרות שלהן על מנת להשתמש בהן. עבור אל Settings (הגדרות) ⚙️ < System (מערכת) < Power Saving (חיסכון בחשמל) < Features Available in Rest Mode (תכונות שזמינות במצב מנוחה).

בחר **Power (הפעלה)** ⏻ ממרכז הבקרה ולאחר מכן בחר **Enter Rest Mode** (היכנס למצב מנוחה). מחווון ההפעלה מהבהב בלבן, ולאחר מכן הופך לכתום. כדי לצאת ממצב מנוחה, לחץ על כפתור (PS).

כיבוי מוחלט של הקונסולה

בחר **Power (הפעלה)** ⏻ במרכז הבקרה ולאחר מכן בחר **Turn Off PS5** (כבה את PS5). מחווון ההפעלה מהבהב בלבן, ולאחר מכן הקונסולה כבה.

טעינת הבקר

כאשר קונסולת PS5 מופעלת או במצב מנוחה, השתמש בכבל USB כדי לחבר את הבקר לקונסולה. כאשר הקונסולה נמצאת במצב מנוחה, שורת האורות בבקר תהבהב באיטיות בכתום. עם השלמת הטעינה, שורת האורות תכבה.

כדי לטעון את הבקר כאשר הקונסולה נמצאת במצב מנוחה, עבור אל Settings (הגדרות) < System (מערכת) < Power Saving (חיסכון בחשמל) < Supply < Features Available in Rest Mode (תכונות זמינות במצב מנוחה) < Power to USB Ports (אספקת חשמל ליציאות USB), ובחר אפשרות שונה מ-Off (כבוי).

שימוש במספר בקרים

באפשרותך להשתמש בו-זמנית ב-4 בקרים או פחות. לחץ על כפתור (PS) כדי להקצות מספרים לבקרים. הנוריות של מחווני השחקנים מאירות בהתאם. מספרים מוקצים לפי סדר מ-1, ותוכל לדעת מה המספר של הבקר שלך לפי מספר הנוריות שמאירות.

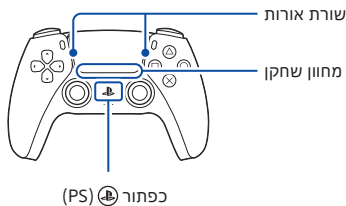

- תצטרך להתאים את הבקר בשימוש הראשון בו (עמוד 4).
- בעת משחק במשחק של PS4, שורת האורות של הבקר מאירה בכחול, אדום, ירוק או כתום, בהתאם לסדר החיבור של הבקרים. דבר זה נפרד ממחווני השחקן.

הפעלת קונסולת PS5 באמצעות בקר

לחץ על כפתור (PS) בבקר שסיים את ההתאמה כדי להפעיל את קונסולת ה-PS5.

השתקת המיקרופון

בכל לחיצה על כפתור ההשתקה, המיקרופון עובר בין מצב מושתק (כפתור מואר) לבין מצב לא מושתק (כפתור כבוי).

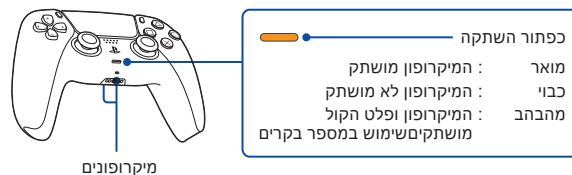

לשחק משחק דיגיטלי

תוכל לשחק במשחק שהורדת מ-PlayStation Store. תקבל הודעה כשהמשחק יסיים לרדת ויהיה מוכן לפעולה. בחר את המשחק ממסך הבית של המשחקים.

- כדי לרכוש ולהוריד משחקים, תצטרך לחבר את הקונסולה לאינטרנט ולהיכנס לחשבון שלך.
- PlayStation™Network ו-PlayStation Store כפופים לתנאי שימוש וכן להגבלות מדינה ושפה. המשתמשים אחראים לעלות שירותי האינטרנט. יחולו עלויות עבור תוכן ו/או שירותים מסוימים. המשתמשים צריכים להיות בגיל 7 ומעלה, ומשתמשים מתחת לגיל 18 חייבים לקבל את הסכמת ההורים. עשויות לחול מגבלות גיל נוספות. זמינות השירות אינה מובטחת. תכן שתכונות מקוונות של משחקים מסוימים יבוטלו בהינתן הודעה מוקדמת בזמן סביר - playstation.com/gameservers. חלים התנאים המלאים: תנאי השירות של PSN נמצאים בכתובת playstation.com/legal/.

לשחק משחק מתקליטור

(רק עבור קונסולות עם כונן תקליטורים מותקן)

הכנס את התקליטור. נתוני המשחק יותקנו, ותקבל הודעה כשהמשחק יהיה מוכן לפעולה. בחר את המשחק ממסך הבית של המשחקים.

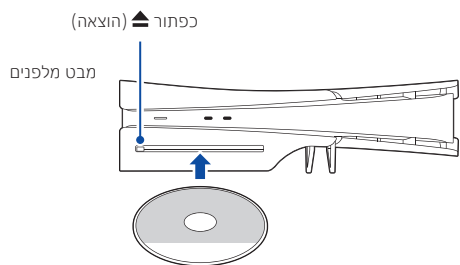

מוציא את התקליטור

לחץ על הכפתור ▲ (הוצאה) כדי להוציא את התקליטור.

מרכז בקרה

לחץ על כפתור (PS) כדי לפתוח את מרכז הבקרה. באפשרותך לגשת למגוון תכונות מבלי לעזוב את המשחק או האפליקציה.



כרטיסים

כרטיסים מציגים תכונות פעילויות שקשורות למשחקים ואפליקציות שזמינים, בהתאם למה שאתה עושה באותו רגע. בחר כרטיס כדי לקבל מידע נוסף, או דלג לכרטיס הבא.

מרכז בקרה

בחר Home (בית) כדי לחזור למסך הבית, ובחר Power (הפעלה) כדי לכבות את קונסולת PS5. בצע פונקציות בסיסיות אחרות כאן, גם כן. קבל גישה מהירה לפונקציות ולהגדרות שבשימוש תכוף במהלך המשחק.

מה מוצג על המסך

Home screen (מסך הבית)

ממסך הבית תוכל לעבור לשני סוגי תוכן: משחקים או מדיה.
במסך הבית של המשחקים, תמצא את המשחקים שלך, PlayStation™Store ואפליקציות אחרות שקשורות למשחקים.
במסך הבית של המדיה, תמצא מוזיקה, וידאו ואפליקציות אחרות שאינן קשורות למשחקים.

מעבר בין מסכי הבית

שנה את ההגדרות וערוך את הפרופיל.

חפשו, שנו הגדרות, וערכו את הפרופיל שלכם.

רכזת

מידע נוסף על המשחק או האפליקציה שבחרת, וחיפוש מידע קשור.

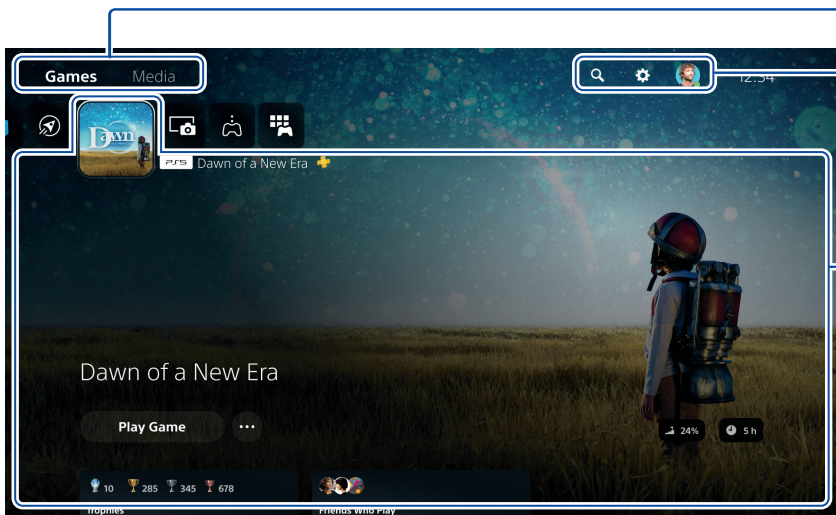

HE

- בקונסולת PS5, הכפתור (X) מאשר את הפריטים שנבחרו.
- כדי לחזור למסך הבית בזמן שמשחק או אפליקציה פועלים, בחר Home (בית) ממרכז הבקרה, או לחץ לחיצה ארוכה על הכפתור (PS) בבקרה.

סמלי דירוג משחק

לכל משחק מוקצה סמל דירוג משחק שמצייע לקבוע אם הוא מתאים לגיל הילד.

אירופה, אפריקה והודו

גיל השחקן	3 ומעלה	7 ומעלה	12 ומעלה	16 ומעלה	18 ומעלה
דירוג הגיל הגבוה ביותר של משחק					

גרמניה

גיל השחקן	0 ומעלה	6 ומעלה	12 ומעלה	16 ומעלה	18 ומעלה
דירוג הגיל הגבוה ביותר של משחק					

מידע נוסף על תכונות והגדרה של בקרת הורים תוכל למצוא ב- User's Guide (מדריך למשתמש) (עמוד 12).

יצירת חשבון עבור ילד

באפשרותך ליצור חשבון ילד ולהגדיר בקרות הורים בו-זמנית. לחצו על כפתור (PS) כדי לפתוח את מרכז הבקרה. בחרו את תמונת הפרופיל שלכם, ואז בחרו **Switch User (החלף משתמש)**. ממסך בחירת המשתמש, בחרו **Add User (הוסף משתמש)** כדי ליצור חשבון.

בדיקה ושינוי של הגדרות בקרת ההורים

אנו ממליצים שתבדוק את בקרות ההורים של הילד באופן סדיר. באפשרותך לבדוק או לעדכן אותן על ידי בחירת **Settings (הגדרות) Family and Parental Controls < ⚙️ (משפחה ובקרות הורים)** במסך הבית.

תוכלו לנהל הגדרות עבור ילדים המשתמשים בקונסולת ה-PS5 שלכם. בקרות הורים מאפשרות לכם להגדיר הגבלות על המשחקים אותם ילדיכם יכולים לשחק, מתי ולמשך כמה זמן הם משחקים, אם הם יכולים לתקשר בצ'אט או לא, ועוד.

כל בוגר (😊) וילד (👶) יזדקק לחשבון נפרד משלו. בעת יצירת חשבון עבור ילד, הוא מקושר אוטומטית לחשבון שלך, ונוצרת משפחה. תוכל להגדיר בקרות הורים רק עבור הילדים במשפחתך.

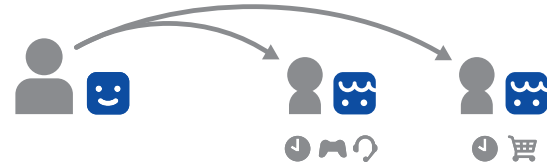

תוכל להשתמש בחשבון קיים, כגון זה שיצרת עבור קונסולת PS4, עבור קונסולת PS5. הגדרות המשפחה ובקרת ההורים יועברו אל קונסולת PS5.

6 חברו את הבקר האלחוטי DualSense® לקונסולה ולחצו על הכפתור (PS).

כדי להתאים את הבקר, חברו אותו באמצעות כבל USB ליציאת USB-ה בקונסולה. כשתלחצו על הכפתור (PS), הבקר יופעל.

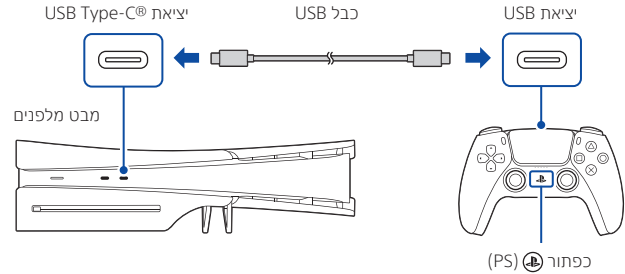

7 צרו חוויה אישית.

כמעט סיימתם! בצעו את ההוראות שעל המסך כדי לסיים את ההגדרה הראשונית.

- הגדירו את החשבון
- צרו חשבון חדש או היכנסו באמצעות חשבון קיים. כניסה באמצעות החשבון הקיים מעניקה לכם גישה למינוי PlayStation®Plus, כמו גם לחברים, לפרסים ולפרטי החשבון האחרים.
- העבירו נתונים מקונסולה אחרת אם יש לכם קונסולת PlayStation®4 או קונסולת PS5 אחרת, תוכלו להעביר נתונים לקונסולה החדשה על ידי כניסה באמצעות חשבון קיים.

תדעו שההגדרה הושלמה כאשר על המסך יופיע **Welcome to PlayStation 5** (ברוכים הבאים ל-PlayStation 5). האם ילד ישתמש בקונסולת PS5? ראו גם "בקרת הורים" (עמוד 5).

- אפשרויות ההגדרה שמוצגות מותאמות לצרכים שלכם, בהתבסס על מידע כגון סביבת הרשת והחשבון שאליו התחברתם.
- תוכלו לחזור ולשנות כל אחת מההגדרות על ידי בחירת **Settings** (הגדרות) ממסך הבית. ⚙️

5 הפעילו את קונסולת PS5 על ידי לחיצה על הכפתור (הפעלה).

מחווון ההפעלה מהבהב בכחול, ולאחר מכן הופך ללבן.

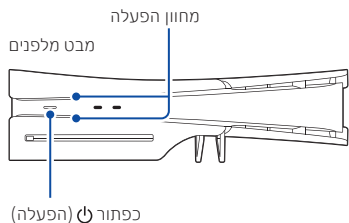

אם תשאירו את הקונסולה במצב סרק במשך 60 שניות לאחר הפעלתה, תכונת קורא המסך תופעל. תוכלו להקשיב לטקסט שעל המסך ולמידע חשוב אחר אשר יוקרא בקול כדי לסייע לכם לבצע את מה שברצונכם לעשות. תכונת קורא המסך זמינה רק בשפות מסוימות.

3 חברו את כבל ה-LAN.

לחיבור חוטי לאינטרנט, השתמשו בכבל LAN (לא מצורף). אם ברצונכם להשתמש ב-Wi-Fi®, אל תחברו כבל LAN ודלגו לשלב הבא.

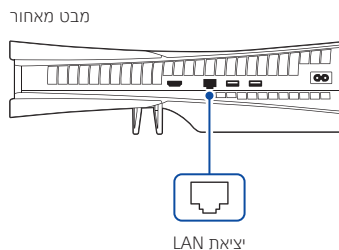

4 הפעילו את הטלוויזיה והגדירו את הקלט ל-HDMI.

1

הכניסו את רגלי המעמד האופקי לתוך החור בחריצים של קונסולת PS5®.

תמיד חברו את הרגליים לקונסולת PS5® לפני השימוש. הניחו את הקונסולה על בד רך הפרוס על פני משטח ישר וחלק לפני שתחברו את הרגליים.

קונסולה עם כונן תקליטורים מותקן

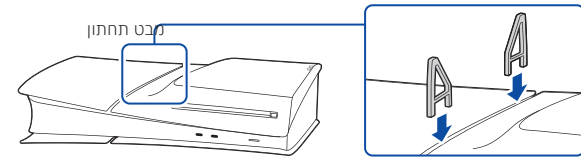

קונסולה ללא כונן תקליטורים מותקן

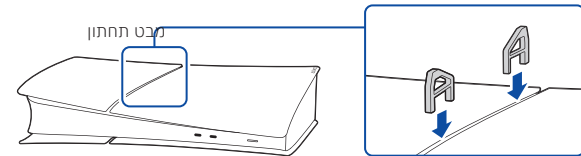

אם ברצונכם להתקין את קונסולת PS5 במצב אנכי, עליכם להשתמש במעמד אנכי (נמכר בנפרד).

2

חברו את כבל ה-HDMI ואת כבל מתח ה-AC.

השתמשו בכבלים המצורפים. יש להשלים את כל החיבורים לפני חיבור כבל מתח ה-AC לאספקת החשמל.

כל האיורים הבאים מציגים את הקונסולה במצב שבו כונן התקליטורים מותקן.

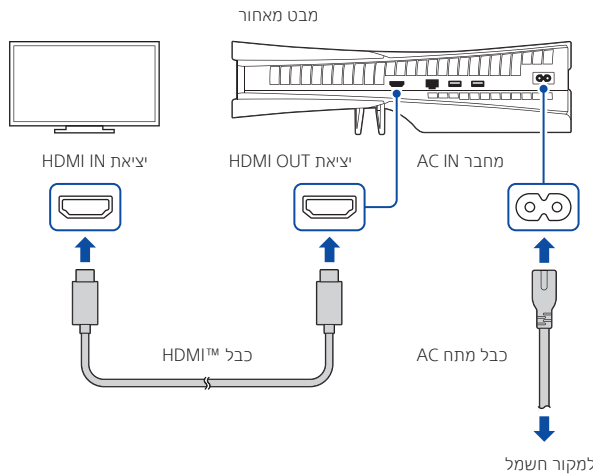

SONY®



PlayStation®5

מדריך להתחלה מהירה